



SABIK



EN





INDEX

1. GENERAL SAFETY INSTRUCTIONS	4
2. GENERAL INSTRUCTIONS	4
2.1. Intended use	4
2.2. Improper use	4
2.3. Warranty	5
3. COMPONENTS / ITEMS DELIVERED	5
3.1. Accessories	6
3.2. Replacement parts	6
4. TECHNICAL DATA	6
4.1. Conditions for installation	6
4.2. Device data	6
4.3. Efficiency	7
4.4. Serial number	7
4.5. Dimensions	8
4.6. Circuit diagram main circuit board	9
5. INSTALLATION (SPECIALISTS)	10
5.1. Instructions on installation	10
5.2. Set Version A or B	10
5.2.1. Overview Version A (delivery standard)	10
5.2.2. Overview Version B	11
5.2.3. Set Version A or B	11
5.2.4. Handing of the unit	12
5.3. Install ventilation system SABIK	12
5.3.1. Fasten wall rail	12
5.3.2. Mount ventilation system	14
5.3.3. Connect condensate line	15
5.4. Install outdoor air and EXHAUST air lines	16
5.5. Connection control panel SABIK-FB	16
6. COMMISSIONING (SPECIALISTS)	18
6.1. Instructions for commissioning	18
6.2. Adjusting flow rates	18
6.2.1. Adjust nominal airflow rate (extract air) according to the curves	18
6.2.2. Adjusting nominal airflow rate (extract air) using differential pressure gauge	24
6.3. Enabling/disabling humidity sensor for automatic mode	28
6.4. Enabling/Disabling VOC sensor (optional accessory) for automatic mode	29
6.5. ENABLING/DISABLING EXTERNAL INPUT 0-10 V	31
6.5.1. General information	31
6.5.2. Activate 0-10 V input through external sensors (Airsens RF-RH/CO2)	31
6.6. Enabling/Disabling fireplace mode	33
6.7. Enabling/Disabling EMERGENCY SHUTDOWN contact	34
6.8. Enabling/Disabling BOOST fan speed	36
6.9. Enabling/Disabling weekly programme	37
7. INDIVIDUAL USER SETTINGS	38
7.1. Set timer for filter alarm	38
7.2. Setting weekly programme	38
8. OPERATION (USERS)	41
8.1. Control panel SABIK-FB	41
8.2. Set fan speed by hand	42
8.3. Switching BOOST on/off	42
8.4. Turn on/off summer bypass	42
8.5. Switching sleep mode on/off	42
8.6. Turn automatic mode on/off	42
8.7. Reset filter alarm	42
8.8. Switch summer mode on/off	42
8.9. Anti-freeze protection	42
9. REDUCED LIST OF MODBUS REGISTERS	43

10. REPAIRING FAULTS.....	45
10.1. Malfunctions.....	45
10.2. Error messages.....	46
11. MAINTENANCE (USERS).....	47
11.1. Replacing filters.....	47
12. MAINTENANCE/REPAIRS (specialists).....	48
12.1. Maintenance periods.....	48
12.2. Logs preventive maintenance.....	48
12.3. Clean ventilation system.....	49
12.4. Clean/replace heat exchanger.....	50
12.5. Clean/replace fan blade.....	51
12.6. Replace main circuit board.....	52
12.7. Replace humidity/temperature sensors.....	53
13. DECOMMISSIONING/DISPOSAL.....	54
13.1. Decommissioning with disassembly.....	54
13.2. Packaging.....	54
13.3. Used devices.....	54
14. PUTTING OUT OF SERVICE AND RECYCLING.....	54
15. ErP DATA.....	55

1. GENERAL SAFETY INSTRUCTIONS



CAUTION

This appliance can be used by children aged from 8 years and above and persons with reduced physical, sensory or mental capabilities or lack of experience and knowledge if they have been given supervision or instruction concerning use of the appliance in a safe way and understand the hazards involved. Children shall not play with the appliance. Cleaning and user maintenance shall not be made by children without supervision.

The following safety instructions must be followed to prevent injuries or damages:

- Before you begin with the installation, operation, maintenance and repair of the ventilation system, read these operating and installation instructions carefully.
- Installation, repairs and electrical work may only be carried out by qualified specialists.
- When installing, commissioning and repairing the ventilation system, you must take into account and obey all necessary legal and national requirements (accident prevention provisions and the generally acknowledged rules of technology).
- While the ventilation system is operating, all covers must be closed.
- If you use a fireplace, whether or not it is dependent on indoor air, you must consult the chimney sweep responsible for the district.
- Keep these operating and installation instructions in a safe place or leave them on the ventilation system, since important information on operation is included in the instructions, see Logs preventive maintenance, p. 48, and page Commissioning log, p. 18.
- Liability for damages that arise due to improper storage, installation, operation or repair, insufficient maintenance or unintended use is excluded.
- We reserve the right to make technical modifications.
- Precautions must be taken to avoid the back-flow of gases into the room from the open flue of gas or other fuel-burning appliances (for duct and partition fans).

Means for disconnection must be incorporated in the fixed wiring according with the wiring rules. An external disconnecting device, which will function as the “designated” disconnect device must be provided, and:

- 1) It shall disconnect the “Line”, while disconnection of the “Neutral” is optional;
- 2) Its OFF-position shall be clearly marked;
- 3) Not to position the equipment so that it is difficult to operate it; and
- 4) The protection current device must be at least 16A, 250V, curve Type C.

If the supply cord is damaged, it must be replaced by the manufacturer, its service agent or similarly qualified persons in order to avoid a hazard.

2. GENERAL INSTRUCTIONS

2.1. INTENDED USE

The ventilation system SABIK is intended for controlled ventilation and venting of single-family houses.

The unit assures a continuous and balanced ventilation system, extracting moist stale air from the wet rooms and at the same time introducing a tempered and filtered fresh air to the habitable rooms.

The unit contains as a standard filters in the supply and extract airflows to clean the incoming air and protect the heat exchanger.

For an easy adaption on site and facilitate the installation the handing (A version = supply/extract on left side; B version= supply/extract on right side) can be selected on the unit. There is also the possibility to connect the supply air on the bottom of the unit.

2.2. IMPROPER USE

Any other use of the ventilation system SABIK not described under “intended use” is prohibited.

Moreover, the ventilation system SABIK may not be installed in a room under +12°C.

The ventilation system SABIK may not be operated without outdoor air filter and extract air filter.

It should only be turned off for maintenance and repair work. Central ventilation systems are, as a rule, designed for continuous operation. Unscheduled shutdown of the ventilation system can lead to formation of condensate inside the piping network and to damages to the ventilation system. For this reason, when shutting down the system for longer periods, the outdoor air and extract air lines must be sealed off.

The ventilation system SABIK is not suitable for drying construction.

2.3. WARRANTY

The unit supplied by S&P is warranted 24 months, parts only, starting from the invoicing date.

S&P agrees to replace the parts or the unit whose operation is recognized defective by our departments except for all damages and interests or penalties such as operating losses, commercial prejudice, or other immaterial or indirect damages.

The following are not covered by our warranty: defects resulting from an abnormal usage or a usage not conforming to the recommendations of our manuals; faults observed as a consequence to normal wear; incidents caused by negligence, lack of monitoring, or servicing; faults due to the incorrect installation of the devices or to bad storage conditions before mounting.

In any case, S&P will not be responsible for transformed unit, repaired even partially.

3. COMPONENTS / ITEMS DELIVERED

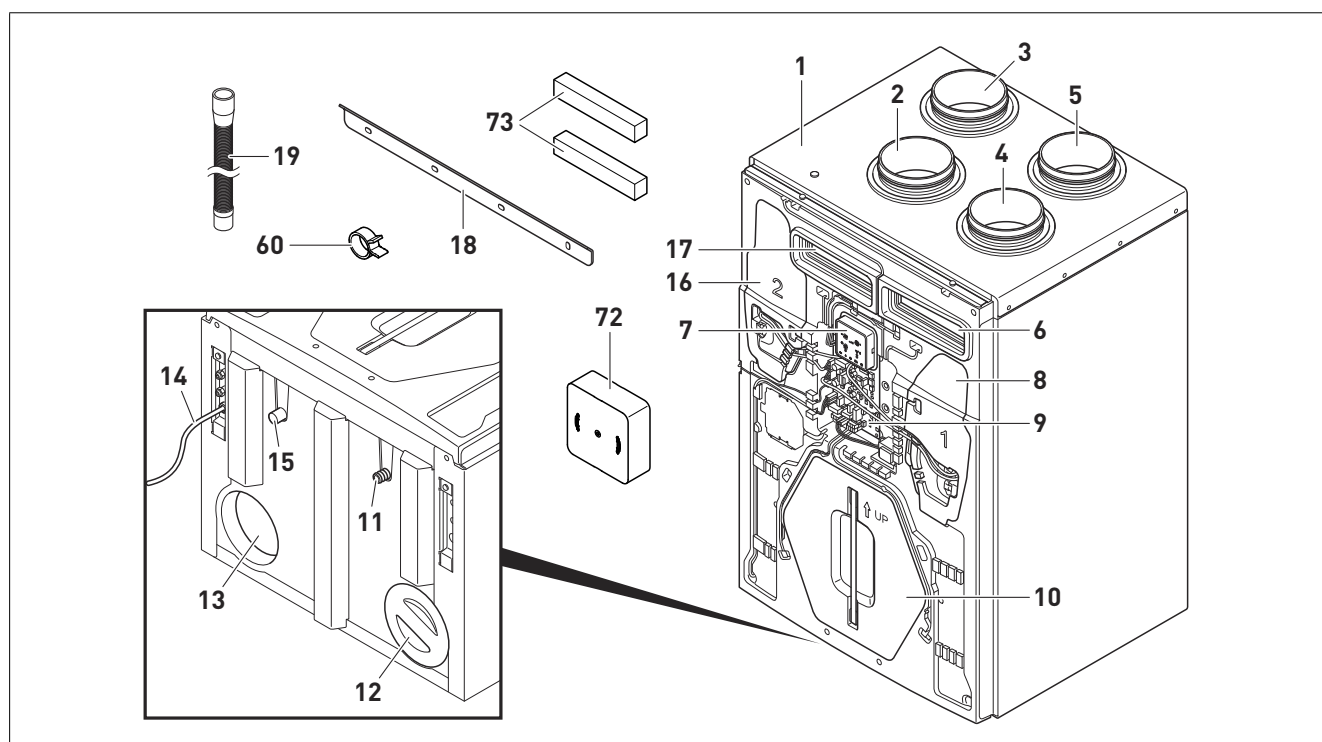

	Version A	Version B
1	Ventilation system SABIK	
2	Connection for extract air	Connection for outdoor air
3	Connection for supply air	Connection for exhaust air
4	Connection for outdoor air	Connection for extract air
5	Connection for exhaust air	Connection for supply air
6	Filter (outdoor air) – ISO Coarse 65% (G4) / optional: ISO ePM1 70% (F7)	Filter (extract air) – ISO Coarse 65% (G4)
7	Control panel (removable)	
8	Fan cover / supply air fan	Fan cover / extract air fan
9	Main circuit board	
10	Heat exchanger	
11	Connection for condensate	Dummy cap for connection for condensate
12	Dummy cover for connection supply air	Connection supply air
13	Connection supply air	Dummy cover for connection supply air
14	Cable for power supply	
15	Dummy cap for connection for condensate	Connection for condensate
16	Fan cover / extract air fan	Fan cover / supply air fan
17	Filter (extract air) – ISO Coarse 65% (G4)	Filter (outdoor air) – ISO Coarse 65% (G4) / optional: ISO ePM1 70% (F7)
18	Wall rail	
19	Flexible connecting hose DN19/23	
60	Clamp for flexible connecting tube DN19/23	
72	Dummy cover control panel	
73	Spacing buffer	



3.1. ACCESSORIES

Item no.	Description
5800017800	SABIK-NEMBUS-SF Servoflow (constant airflow kit)
5800023300	SABIK210-PH Preheater
5800018300	SABIK350-PH Preheater
5800018400	SABIK500-PH Preheater
5800018900	SABIK-VOC VOC-sensor
5800025400	SABIK-WMC Wall bracket deep
5800046700	SABIK210-F-G4G4 Replacement filterset (ISO coarse 65%)
5800046800	SABIK210-F-G4F7 Replacement filterset (ISO coarse 65%/ISO ePM1 70%)
5800046900	SABIK350-F-G4G4 Replacement filterset (ISO coarse 65%)
5800047000	SABIK350-F-G4F7 Replacement filterset (ISO coarse 65%/ISO ePM1 70%)
5800047100	SABIK500-F-G4G4 Replacement filterset (ISO coarse 65%)
5800047200	SABIK500-F-G4F7 Replacement filterset (ISO coarse 65%/ISO ePM1 70%)

3.2. REPLACEMENT PARTS

Item no.	Description
R153139001	SABIK 210-M1 Fan M1
R153139007	SABIK 210-M2 Fan M2
R153139101	SABIK 350-M1 Fan M1
R153139107	SABIK 350-M2 Fan M2
R153139201	SABIK 500-M1 Fan M1
R153139207	SABIK 500-M2 Fan M2
R153139016	SABIK 210-PL Main circuit board
R153139116	SABIK 350-PL Main circuit board
R153139216	SABIK 500-PL Main circuit board
R153139037	SABIK-TFF Temperature/humidity sensor
R153139052	SABIK-NEMBUS-HRE Preheater PCB
R153139024	SABIK-NEMBUS-FB Remote control
R153139009	SABIK 210-HRPTC Preheater module w/o PCB
R153139109	SABIK 350-HRPTC Preheater module w/o PCB
R153139209	SABIK 500-HRPTC Preheater module w/o PCB
R153139002	SABIK 210-WT Heat exchanger
R153139102	SABIK 350-WT Heat exchanger
R153139202	SABIK 500-WT Heat exchanger
R153139020	SABIK 210-FD Front cover
R153139120	SABIK 350-FD Front cover (SABIK 350 and SABIK 500 are identically)
R153139023	SABIK 210-FA Filter cover
R153139123	SABIK 350-FA Filter cover (SABIK 350 and SABIK 500 are identically)

4. TECHNICAL DATA

4.1. CONDITIONS FOR INSTALLATION

Ambient temperature installation site	+12°C to +40°C
Minimum outdoor air temperature (Including preheater [optional accessory])	-15°C
Environmental conditions	Non-saline, no aggressive chemicals, no risk of explosion

4.2. DEVICE DATA

Weight:	
SABIK 210	34.0 kg
SABIK 350	45.0 kg
SABIK 500	56.0 kg
Materials:	
Front cover	Plastic
Casing of device	Steel sheet
Filter covers	Plastic
Body of device	EPP
Connection for condensate	DN20
Supply voltage	230 V AV, 50 Hz Safety plug
Max. power input	
SABIK 210	$P_{max.} = 87 \text{ W}$, $I_{max.} = 0.67 \text{ A}$
SABIK 350	$P_{max.} = 145 \text{ W}$, $I_{max.} = 0.98 \text{ A}$
SABIK 500	$P_{max.} = 265 \text{ W}$, $I_{max.} = 2.1 \text{ A}$
Nominal airflow rate (extract air):	
Air volume SABIK 210	Up to 140 m ³ /h at 100 Pa
Air volume SABIK 350	Up to 250 m ³ /h at 100 Pa
Air volume SABIK 500	Up to 380 m ³ /h at 125 Pa
Speed regulation	Four-level
Direct-current fans	2 pieces, angled backwards
SABIK 210	DN 160
SABIK 350	DN 190
SABIK 500	DN 220
Countercurrent heat exchanger	Plastic
Connection outdoor and exhaust air lines	S&P IPP46
Filters	Filter quality extract air: • ISO Coarse 65% (G4) Filter quality outdoor air: • ISO Coarse 65% (G4) • Optional: ISO ePM1 70% (F7)
Control panel with cable	Removable
Programming	Four pre-set programmes
Protection class	IP21

4.3. EFFICIENCY

NOTE

Fan speed V1 serves for humidity protection when living areas are empty. Use this fan speed only when nobody is there.

	Factory setting
Fan speed V1	Humidity protection (☹️)
Fan speed V2	Reduced ventilation (🌬️)
Fan speed V3	Nominal airflow (🌬️🌬️)
BOOST	Intensive ventilation (🌬️🌬️🌬️)

4.4. SERIAL NUMBER

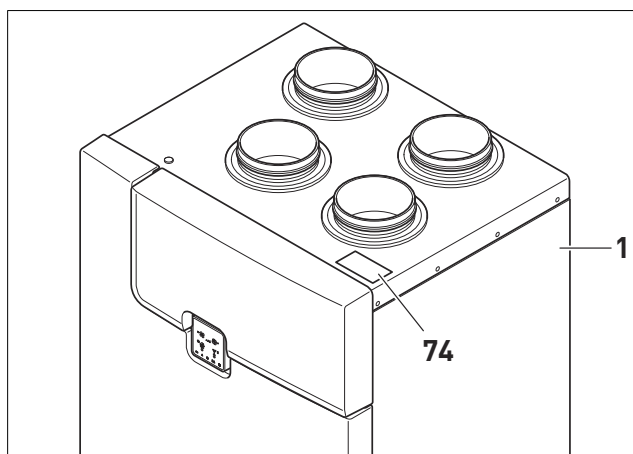

The serial number is located on the nameplate (74) at the upper right on the ventilation system (1).

4.5. DIMENSIONS

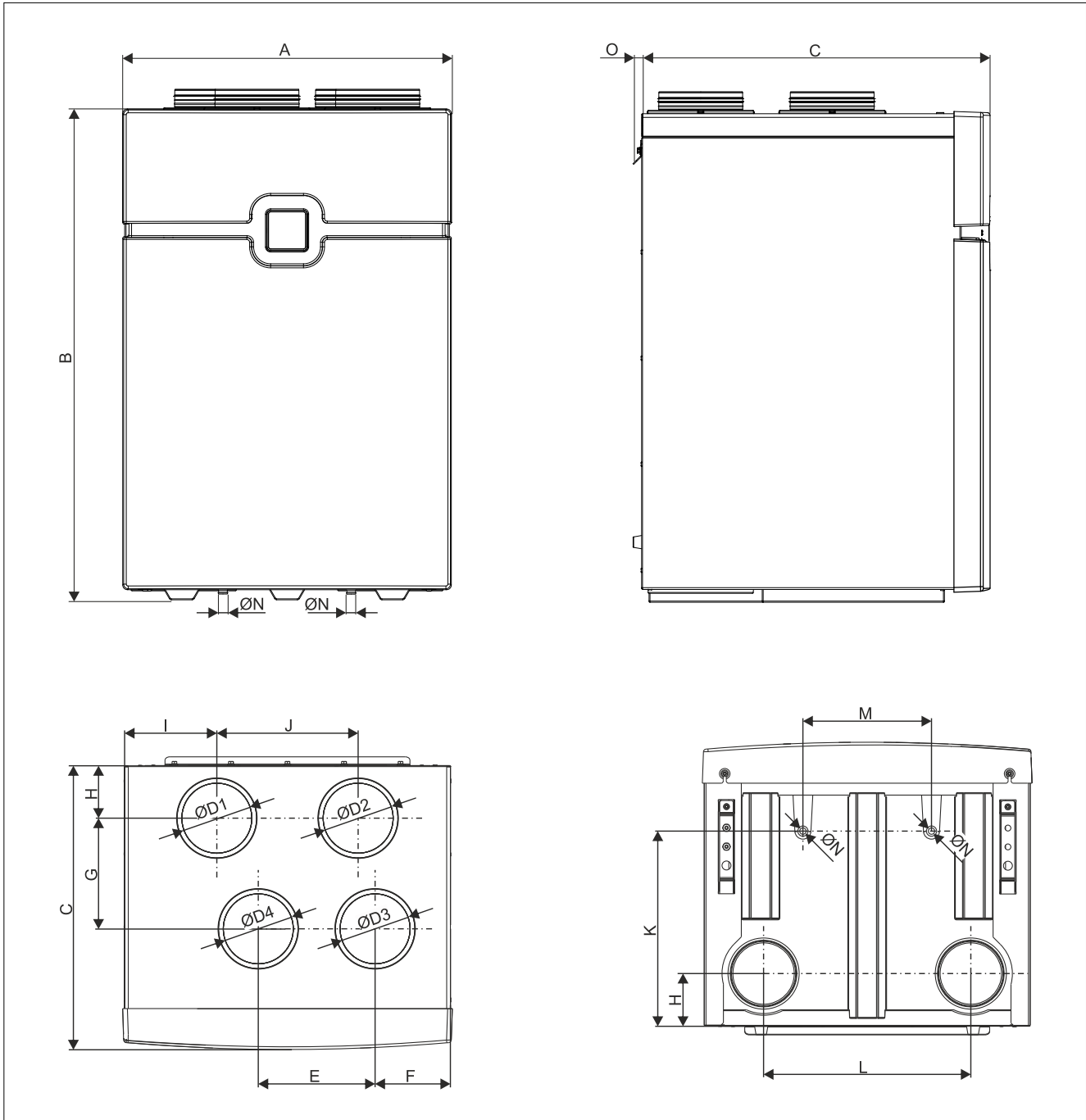

	Dimension [mm]																	
	A	B	C	D1	D2	D3	D4	E	F	G	H	I	J	K	L	M	N	O
SABIK 210	600	995	460	125	125	125	125	215	125	180	94	161	215	313	392	267	21	19
SABIK 350	700	1046	603	150	150	150	150	248	160	235	111	196	300	414	440	273	21	19
SABIK 500	700	1046	753	180	180	180	180	257	153	280	126	196	300	493	440	273	21	19

4.6. CIRCUIT DIAGRAM MAIN CIRCUIT BOARD

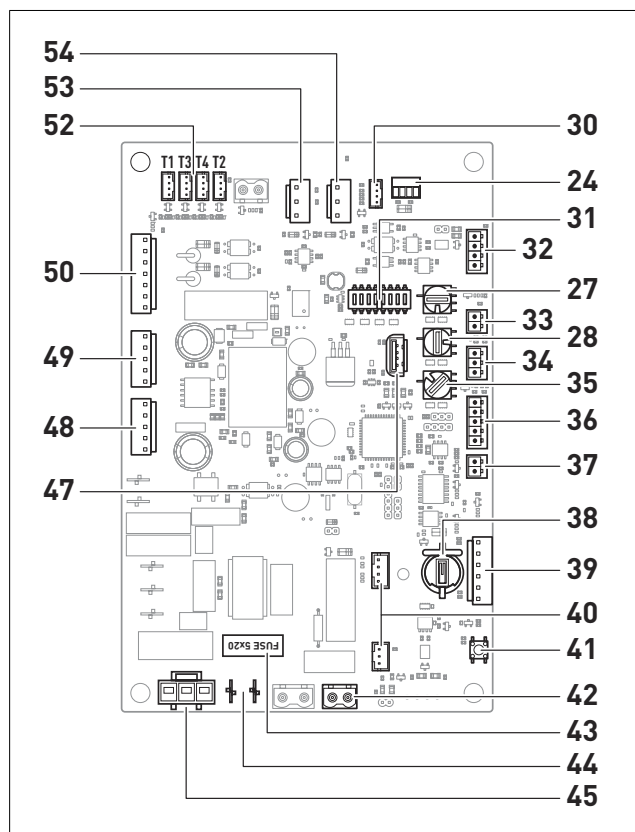

- 30** Connection VOC sensor (optional accessory)
- 24** Connection control panel SABIK-FB
- 31** Dip switches for setting ventilation system
- 32** Modbus RTU connection / Connection for communication module SPCM (optional accessory)
- 27** Potentiometer for adjusting nominal airflow rate (extract air) (factory setting Position 4)
- 33** Connection fan speed BOOST
- 28** Potentiometer for adjustment of the ratio of flow rates between supply and extract air (factory setting Position 0)
- 34** Connection 0-10 V signal (optional accessory)
- 35** Potentiometer for target setting of humidity sensor or VOC sensor (optional accessory) (factory setting Position A)
- 36** Connection of pressure sensor for constant pressure regulation
- 37** Contact EMERGENCY SHUTDOWN
- 38** Button cell type CR1220 for storing time
- 39** Connection preheater (optional accessory)
- 40** Connection ServoFlow Kit (optional accessory) - constant airflow
- 41** Reset (factory setting)
- 42** Potential-free contact (closed when unit OFF)
- 43** Microfuse F5L250V
- 44** Harmonics filters
- 45** Voltage supply preheater
- 47** USB connection for software updates
- 48** Voltage supply M1
- 49** Voltage supply M2
- 50** Connection summer bypass
- 52** Connection temperature/humidity sensors
- 53** Control signals M2
- 54** Control signals M1

5. INSTALLATION (SPECIALISTS)



CAUTION

The ventilation system may only be installed by qualified specialists, otherwise there is risk of injury or damages.



CAUTION

In order to protect the system from dirt and humidity, all openings must be sealed, e.g. using a construction protector, until commissioning.

5.1. INSTRUCTIONS ON INSTALLATION

- As far as construction, the shell must be finished and the entire wall structure of the interior and exterior walls must be completed.
- During construction, the core holes must be made in the exterior wall for the outdoor and exhaust air lines.
- The ventilation system can be installed in dry rooms above +12°C, for example in the utility room.

NOTE

If the temperature in the installation area drops below +12°C, then in individual cases condensate may form on the device casing.

- Position the ventilation system and set Version A or B so that the outdoor air and exhaust air lines can be conducted out of the building by the shortest path.
- The ventilation system must be installed with noise coupling.
- The ventilation system must be easily accessible for all maintenance and repair work.
- Set airflows.
- Start operation of the ventilation system only after completion of all installation tasks.

5.2. SET VERSION A OR B

For flexible installation of the ventilation system, the device can be switched over at the installation site. To do so, the configuration of air connections and of the condensate connection is modified.

5.2.1. Overview Version A (delivery standard)

Air connections

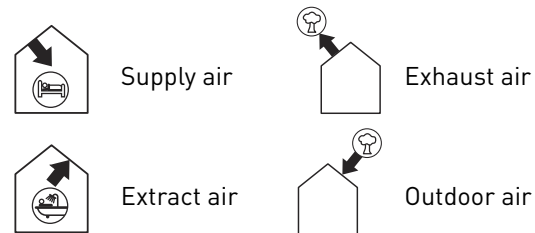
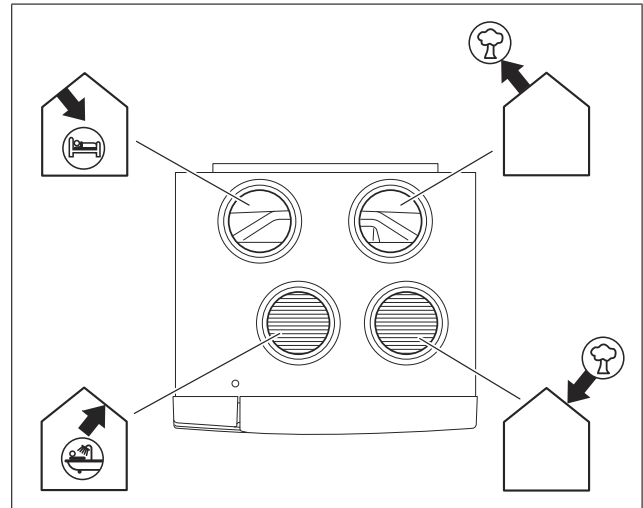

Connection for condensate

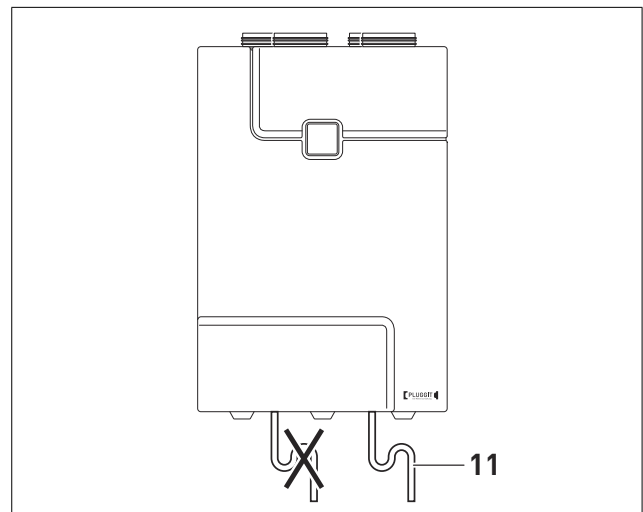

Utilise connection for condensate [11]. Make sure that the other condensate connection is closed.

5.2.2. Overview Version B

Air connections

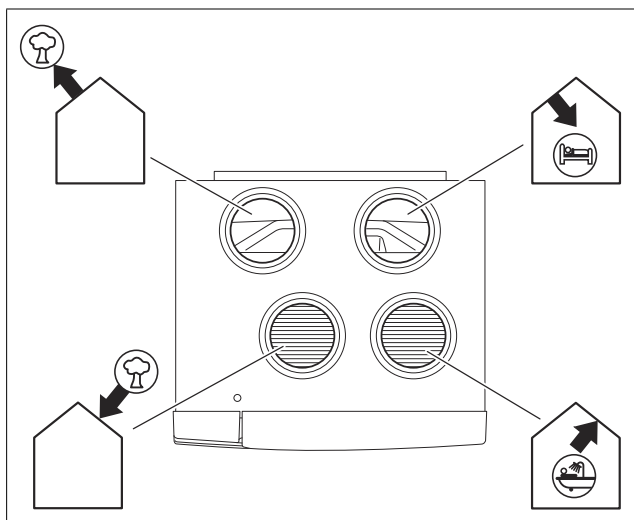

Connection for condensate

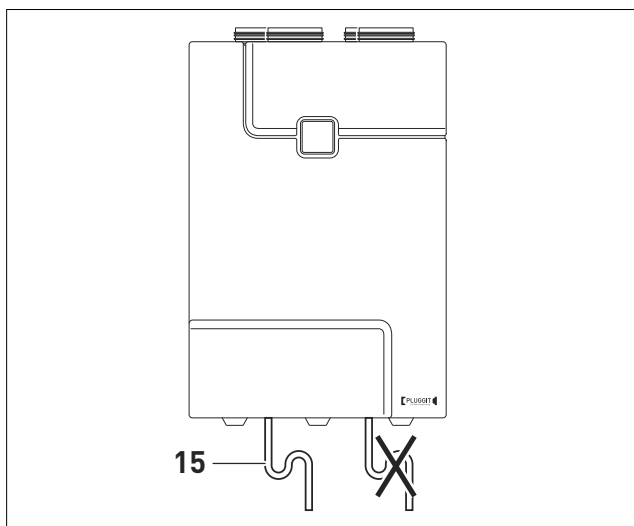

Utilise connection for condensate (15). Make sure that the other condensate connection is closed.

5.2.3. Set Version A or B

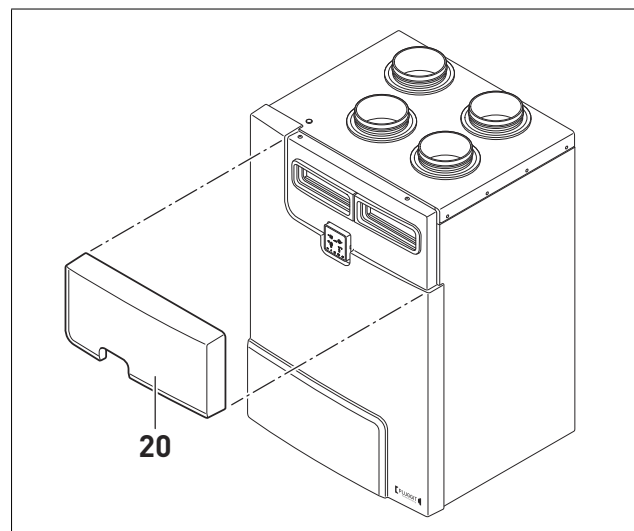

1. Disconnect the unit from the power supply.
2. Remove filter cover (20).

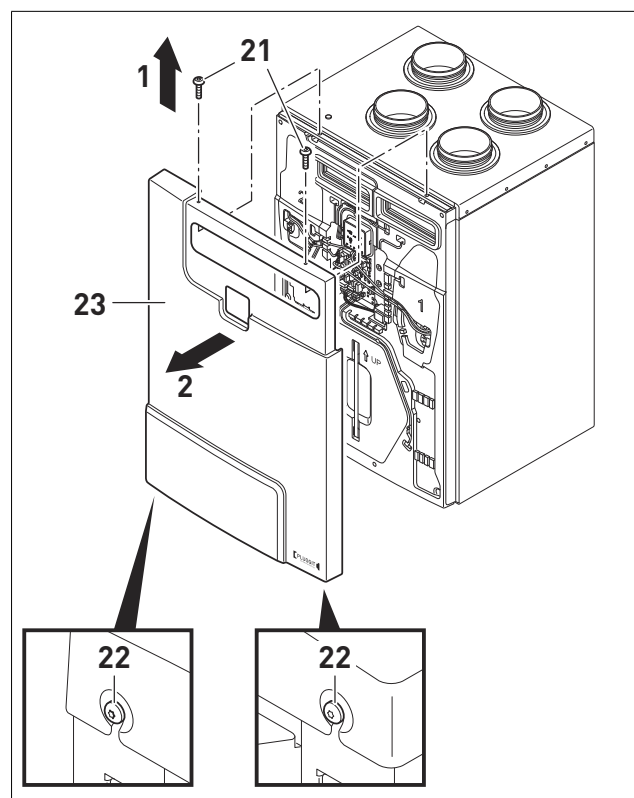

3. Loosen screws Torx 30 (22) on the bottom of the device.
4. Unscrew screws Torx 30 (21) on top of device (Arrow 1).
5. Remove front cover (23) (Arrow 2).

5.2.4. Handing of the unit

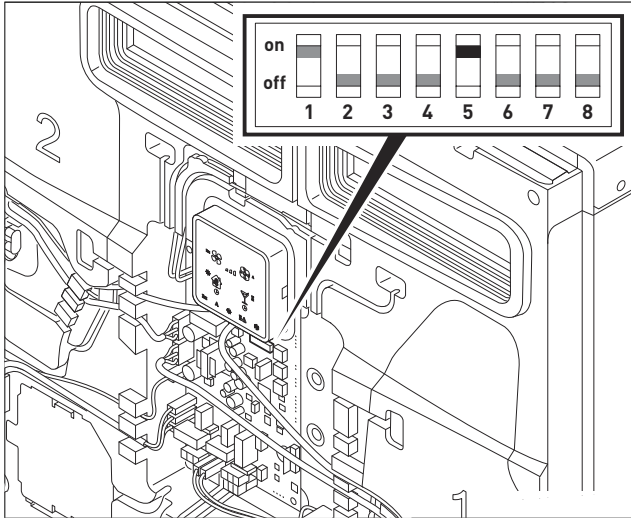

6. Set dip switch 5 to the desired position.
 on = Version A (factory setting)
 off = Version B

5.3. INSTALL VENTILATION SYSTEM SABIK

NOTE

All the following descriptions are depicted on the ventilation device of Version A (as delivered). To install the ventilation device to the switched over Version B, proceed in a similar manner. The ventilation system must be easily accessible for all maintenance and repair work.

5.3.1. Fasten wall rail

Wall rail from among the items delivered

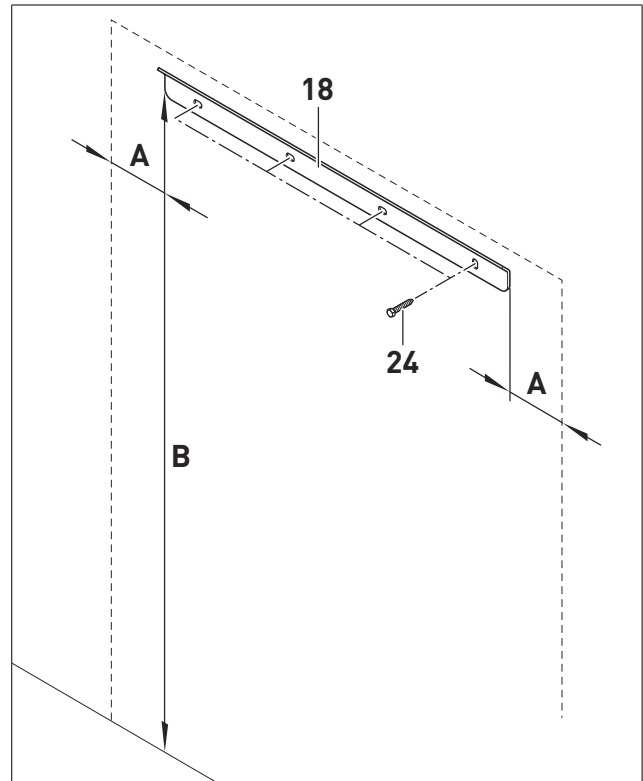

- Position the wall rail (18) in a horizontal position and drill holes.
 - A** min. 200 mm
(from the wall on the left and right sides)
 - B** distance condensate connection plus height ventilation system, see p. 8.
- Screw wall rail on tightly (18) with screws (24).

NOTE

Screws (24) are not included in items delivered. Select screws (24) with appropriate dowels for the brickwork.

Wall rail SABIK-WMC (optional accessory)

If the outdoor and outgoing air are conducted to the outside directly behind the ventilation system, then the distance between the wall and the device may be too small after installation of the wall rail included among the parts delivered, when relevant.

If needed this wall rail can be substituted by the wall rail SABIK-WMC (optional accessory).

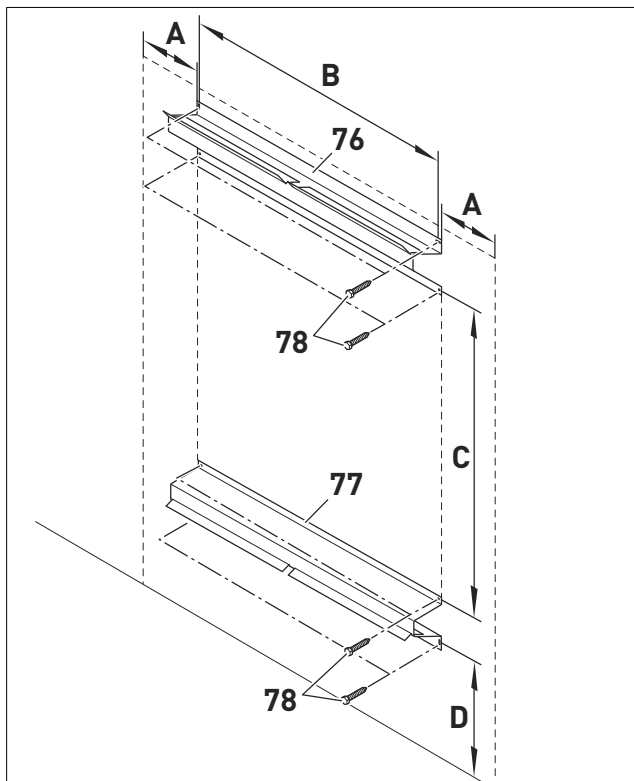

1. Place wall rail SABIK-WMC (76) and (77) in a horizontal position and create drill holes.

A min. 200 mm
(away from the wall on the right or left side)

B 565 mm

C 655 mm

D 390 mm

(including space needed for condensate connection)

2. Fasten wall rail SABIK-WMC (76) and (77) with screws (78).

NOTE

Screws (78) are not included in items delivered. Select screws (78) with appropriate dowels for the brickwork.

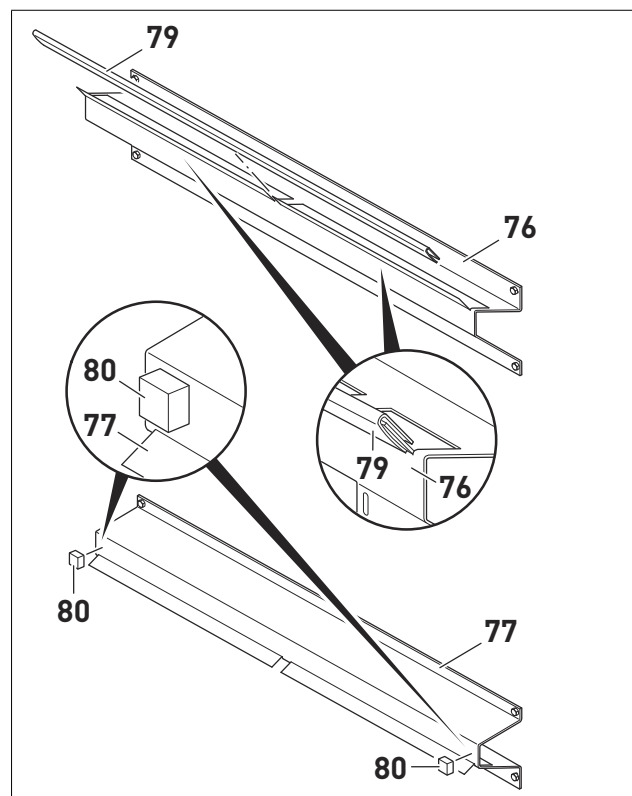

3. Push rubber lip (79) onto wall rail SABIK-WMC (76).

4. Attach rubber buffer (80) to wall rail SABIK-WMC (77).

5.3.2. Mount ventilation system

NOTE

The following description illustrates the mounting of the ventilation system using the wall rail from among the delivered items.

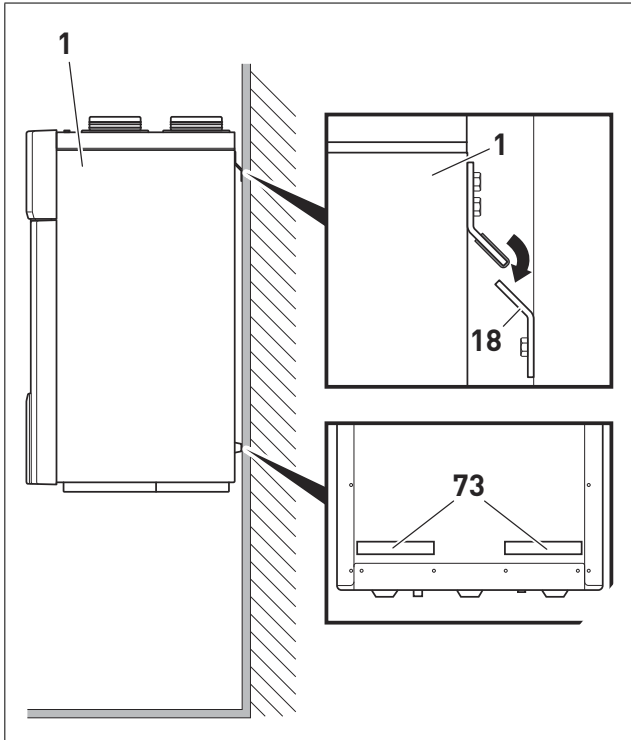

1. Affix spacing buffer [73] permanently within the indicated area on the back of the ventilation system (1).
2. Mount ventilation system (1) on wall rail (18).
3. Monitor vertical and horizontal mounting of the ventilation system (1) using spirit level.

5.3.3. Connect condensate line

NOTE

The following description is a suggestion for installation of the condensate line.

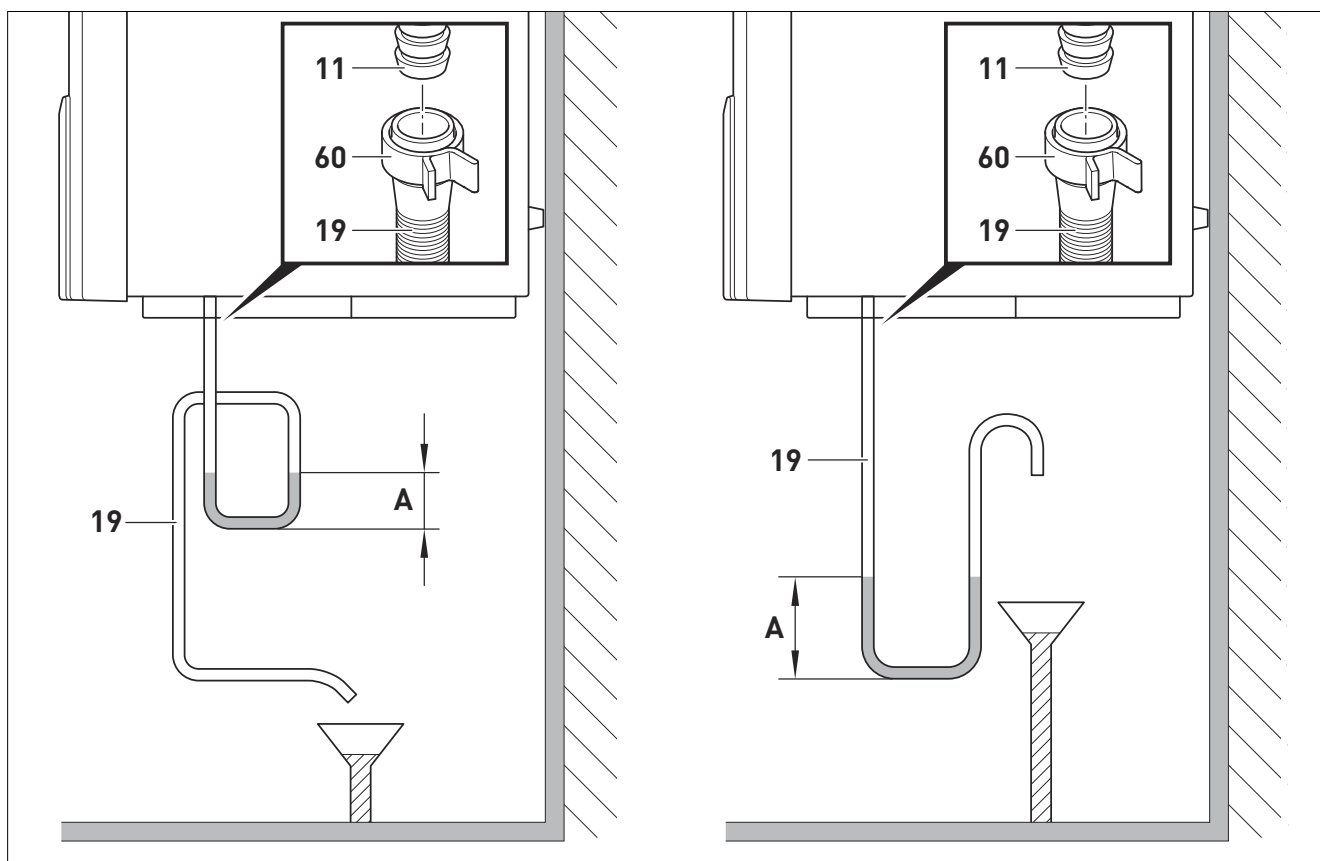

1. Fasten condensate line (19) with connection side DN19 with enclosed clamp (60) onto the condensate connection (11), and mount it in a siphon loop onto a funnel or a siphon.

NOTE

When converting the ventilation system to Version B, use condensate connection (15). See "5.2.2. Overview Version B", see p. 11.

2. Fill condensate duct (19) with water. Minimum level: 100 mm (dimension A).
The condensate connection that will not be used has to be closed!

5.4. INSTALL OUTDOOR AIR AND EXHAUST AIR LINES

NOTE

It is indispensable install insulated duct on the outdoor air and exhaust air side in order to avoid condensation!

5.5. CONNECTION CONTROL PANEL SABIK-FB

NOTE

The control panel can be installed on the wall (surface-mounted), if needed, with a maximum length of 30 m. Recommended cable: 4 x 0,25 mm², shielded twisted-pair cable (not included).

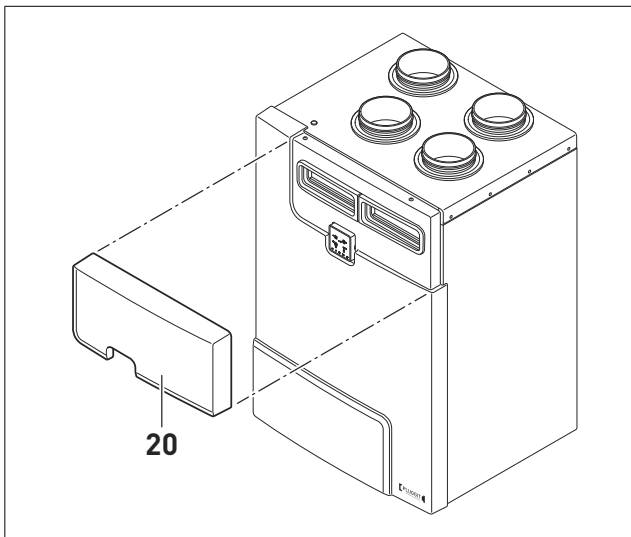

1. Remove filter cover [20].

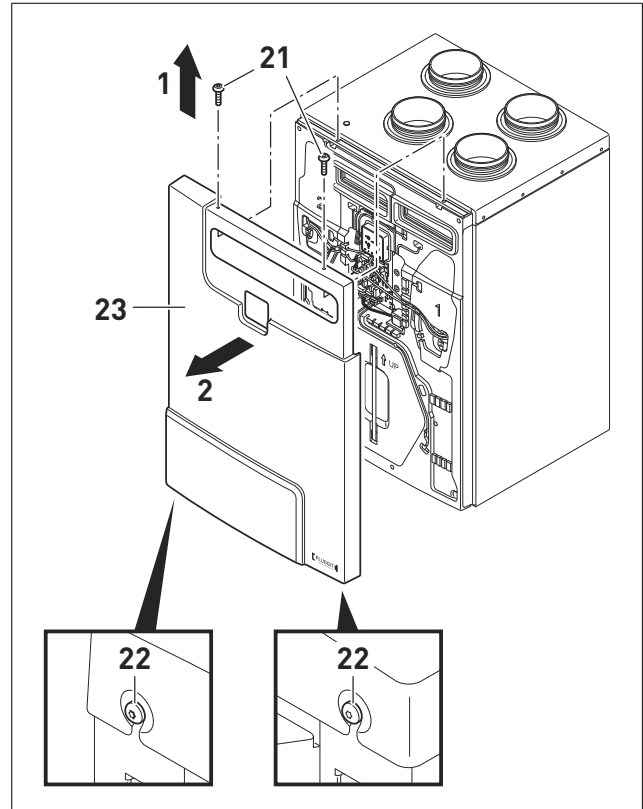

2. Loosen screws Torx 30 [22] on the bottom of the device.
3. Unscrew screws Torx 30 [21] on top of device (Arrow 1).
4. Remove front cover [23] (Arrow 2).

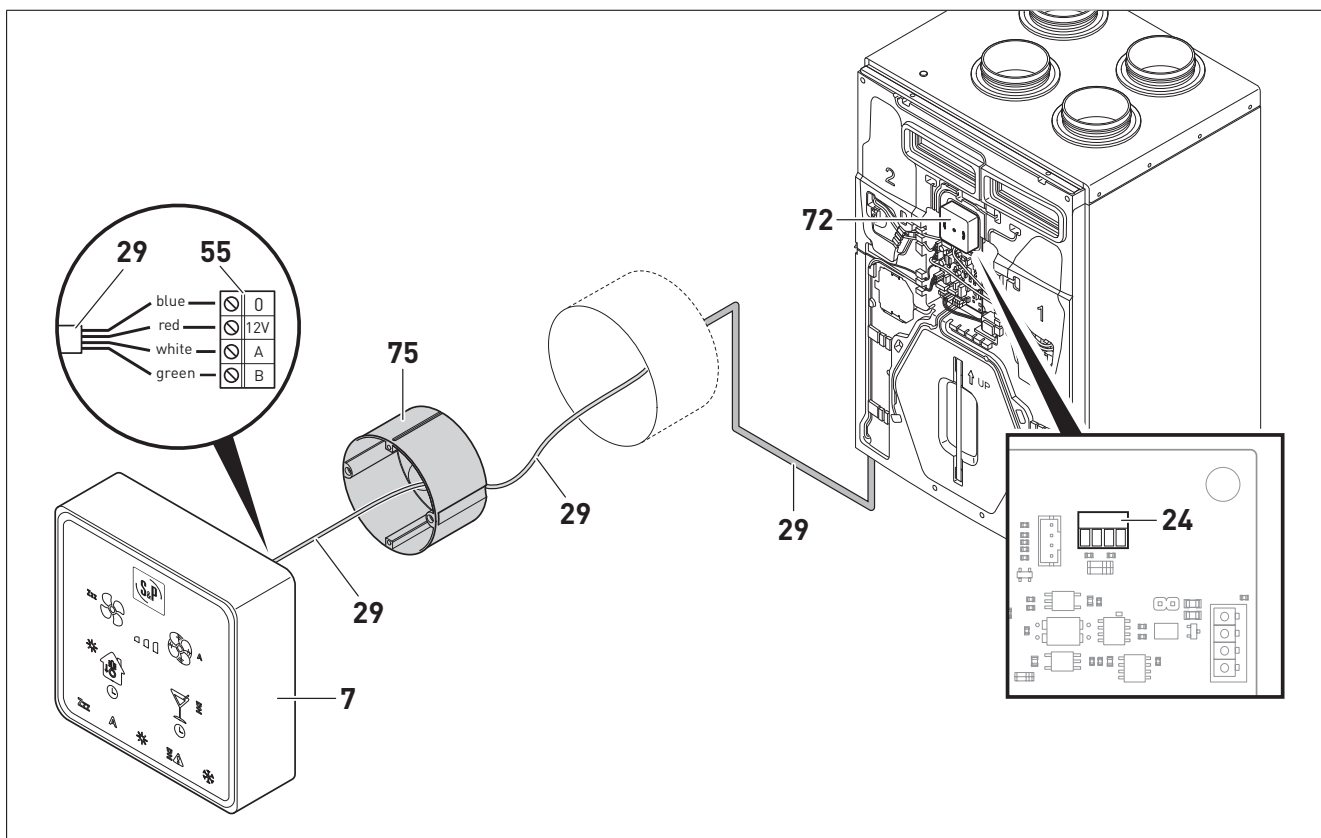

5. Remove control panel (7) from the ventilation system and insert dummy cover (72) into the ventilation system.
6. Connect cables (29) to the connection (24).

8. Conduct cables (29) from the wall opening into the flush-mounted box (75).

NOTE

Flush-mounted box (75) and cable (29) are not included in the items delivered and must be provided on construction.

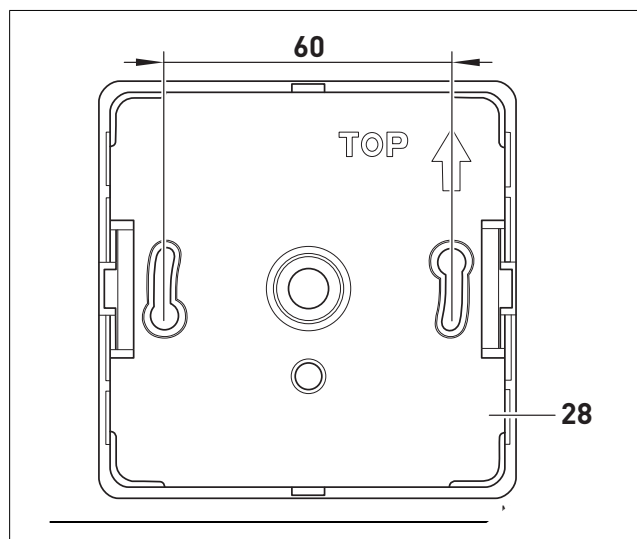

7. Drill holes for cover of control panel (28) at the intended installation location.

9. Insert flush-mounted box (75) in wall opening.
10. Connect cables (29) to plugs (55).
11. Insert control panel (7) into flush-mounted box (75) and screw on tightly.

NOTE

No screws are included in the delivered parts. Select screws with dowels appropriate for the brickwork.

12. Connect ventilation system to power supply.

6. COMMISSIONING (SPECIALISTS)



CAUTION

The ventilation system may only be commissioned by qualified specialists, otherwise there is risk of injury or damages.

NOTE

All the following descriptions are depicted on the ventilation device of Version A (as delivered). To install the ventilation system in the switched over Version B, proceed in a similar manner, see Set Version A or B, p. 10.

6.1. INSTRUCTIONS FOR COMMISSIONING

- Before commissioning, the system including all ducts must be checked for possible pollution residues or foreign bodies and cleaned.
- All electrical safety features are properly connected and configured and in working order.

6.2. ADJUSTING FLOW RATES

The flow rates can be adjusted using the curves or according to differential pressure measured at the pressure taps.

The condensate duct must be installed before adjusting the flow rates. There must be a water seal at the condensate connection. Check this and secure it.

6.2.1. Adjust nominal airflow rate (extract air) according to the curves

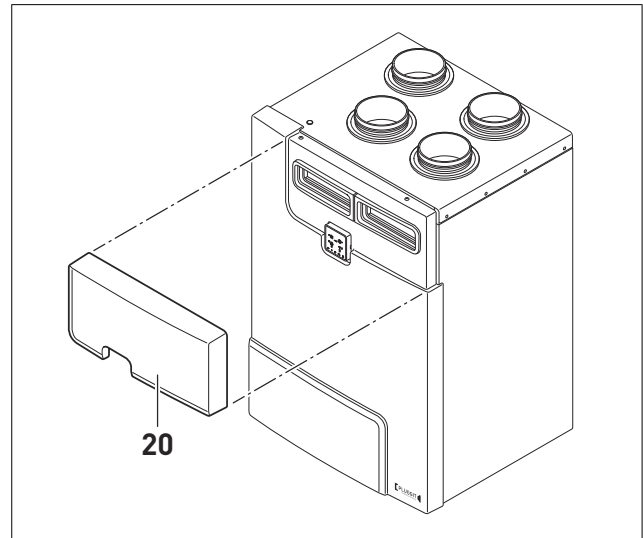

1. Remove filter cover (20).

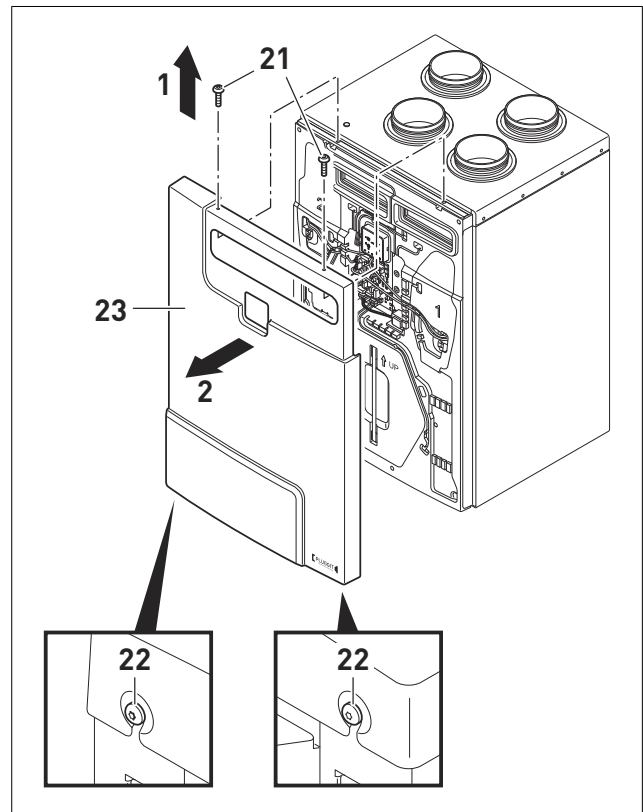

2. Loosen screws Torx 30 (22) on the bottom of the device.
3. Unscrew screws Torx 30 (21) on top of device (Arrow 1).
4. Remove front cover (23) (Arrow 2).

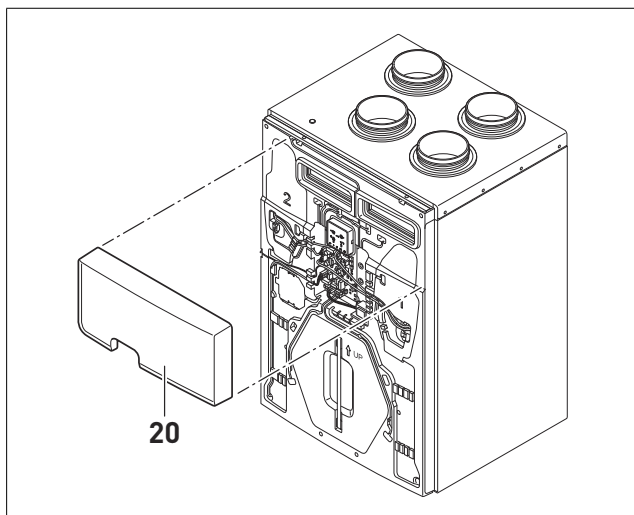

5. Reinsert filter cover (20).
6. Set up power supply of the ventilation system.
7. Switch on fan speed V3 on the control panel, see Set fan speed by hand, p. 42.

NOTE

The values from the diagrams below refer to setting fan speed V3.

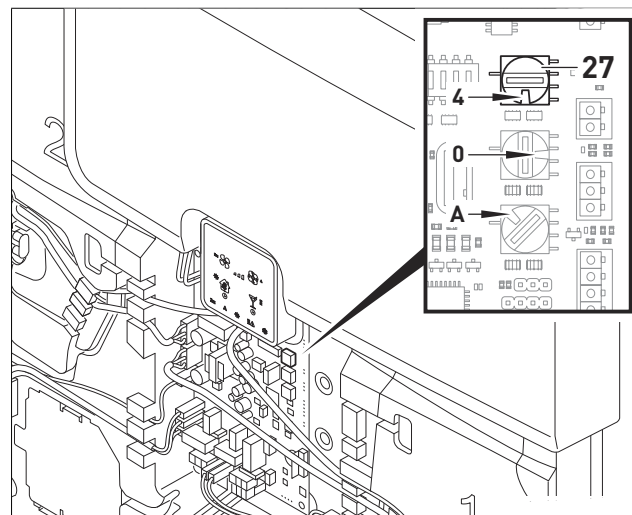

8. The nominal airflow volume (extract air) can be set using the curves with the potentiometer (27), see the following diagram.
 In the factory setting, the potentiometer (27) is at Position 4. When setting the operating point, S&P recommends assuming a system operating pressure of 100 Pa (if the real pressure cost is not known). It must be set to the value of the curve that is closest to the intersection point between the nominal airflow rate and 100 Pa. Then, the extract and supply airflows must be checked and if needed a readjustment must be made with the potentiometer (27) (extract air) and the potentiometer (28) (supply air).
 As an alternative, the flow rates can be set by measuring the differential pressure or by the ServoFlow Kit (constant airflow module as an optional accessory).



SABIK 210

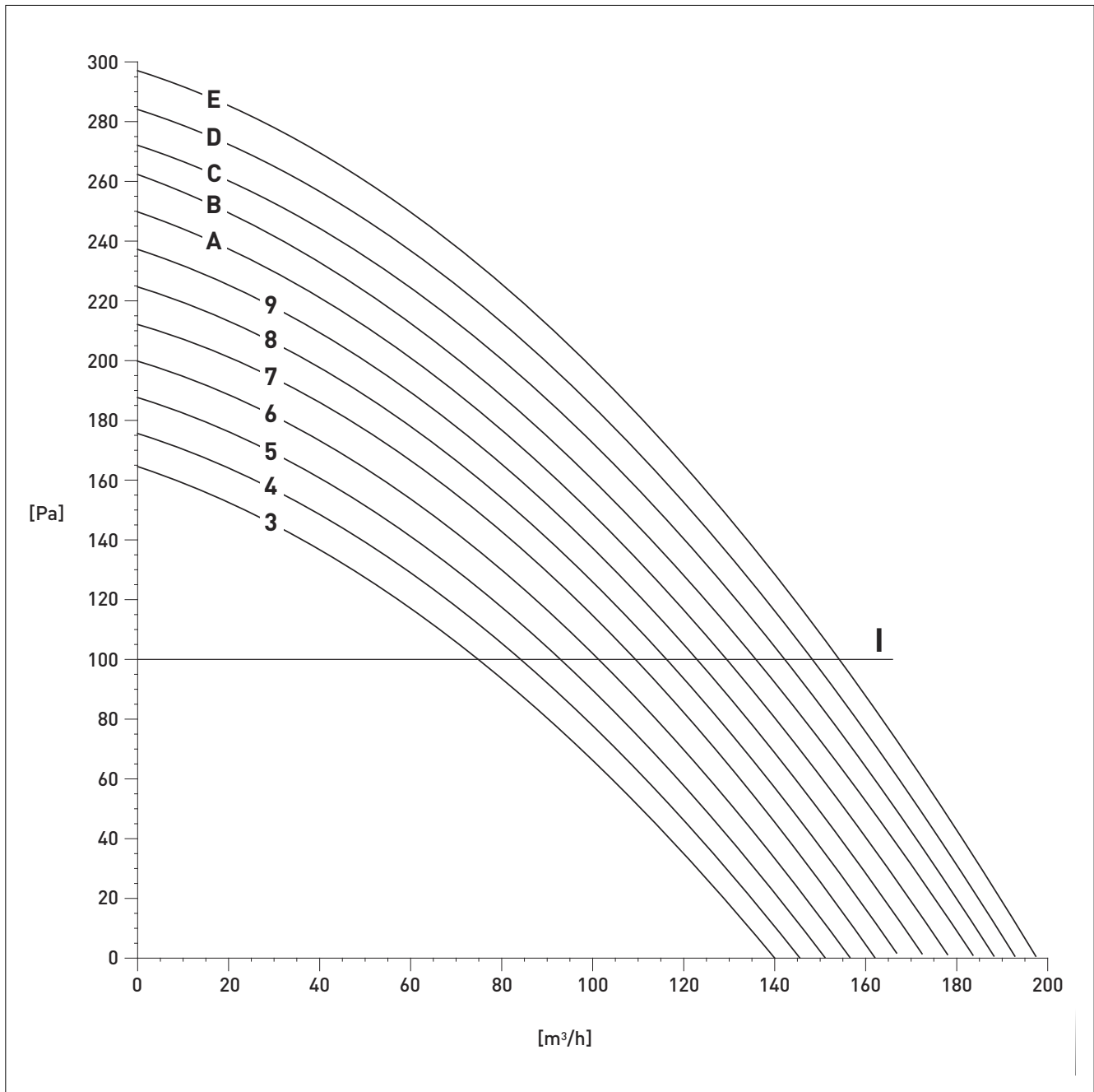

[Pa] Pressure loss

[m³/h] Nominal flow rate (extract air)

I Supposed system operating pressure

SABIK 350

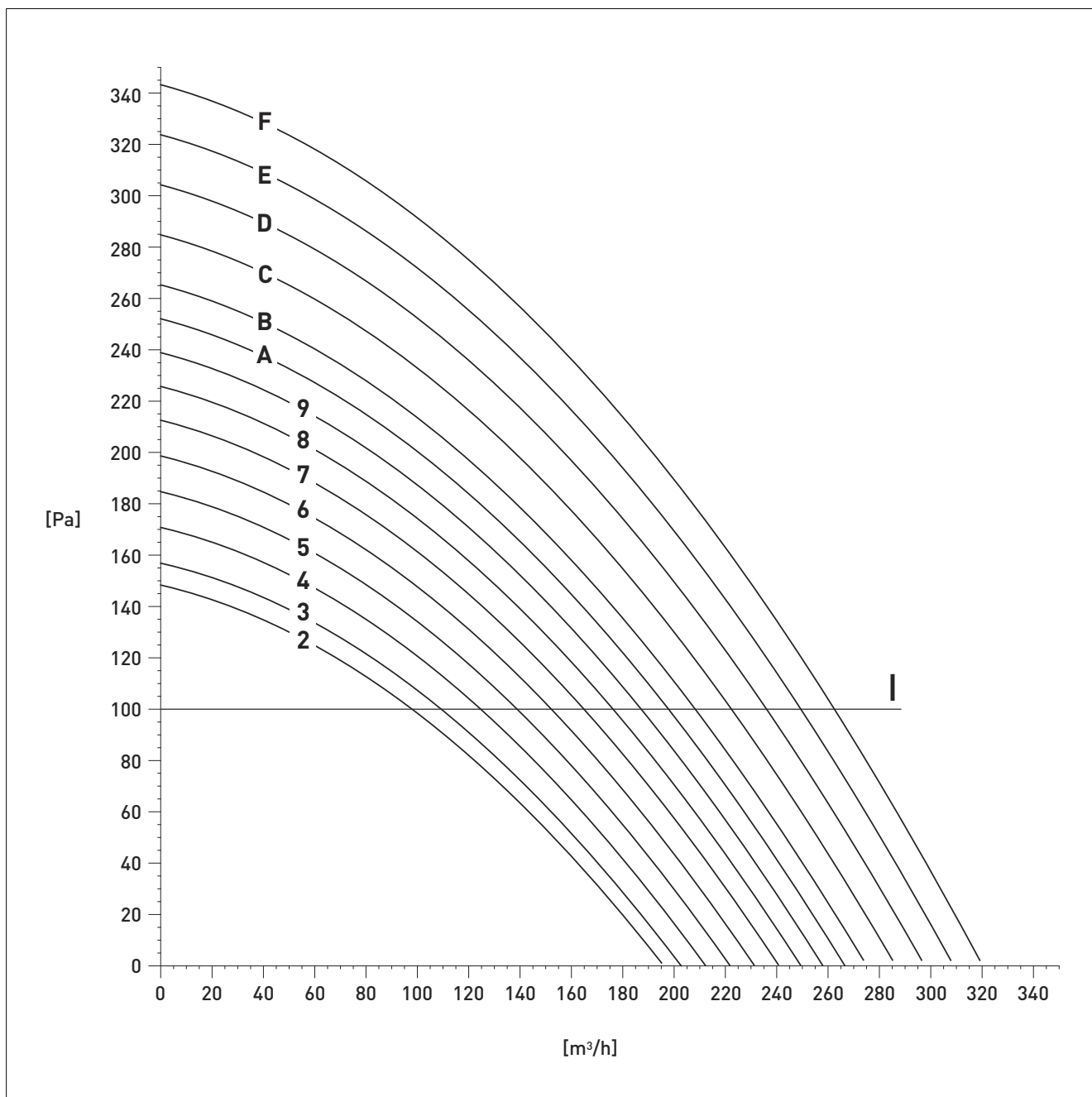

[Pa] Pressure loss

[m³/h] Nominal flow rate (extract air)

I Supposed system operating pressure



SABIK 500

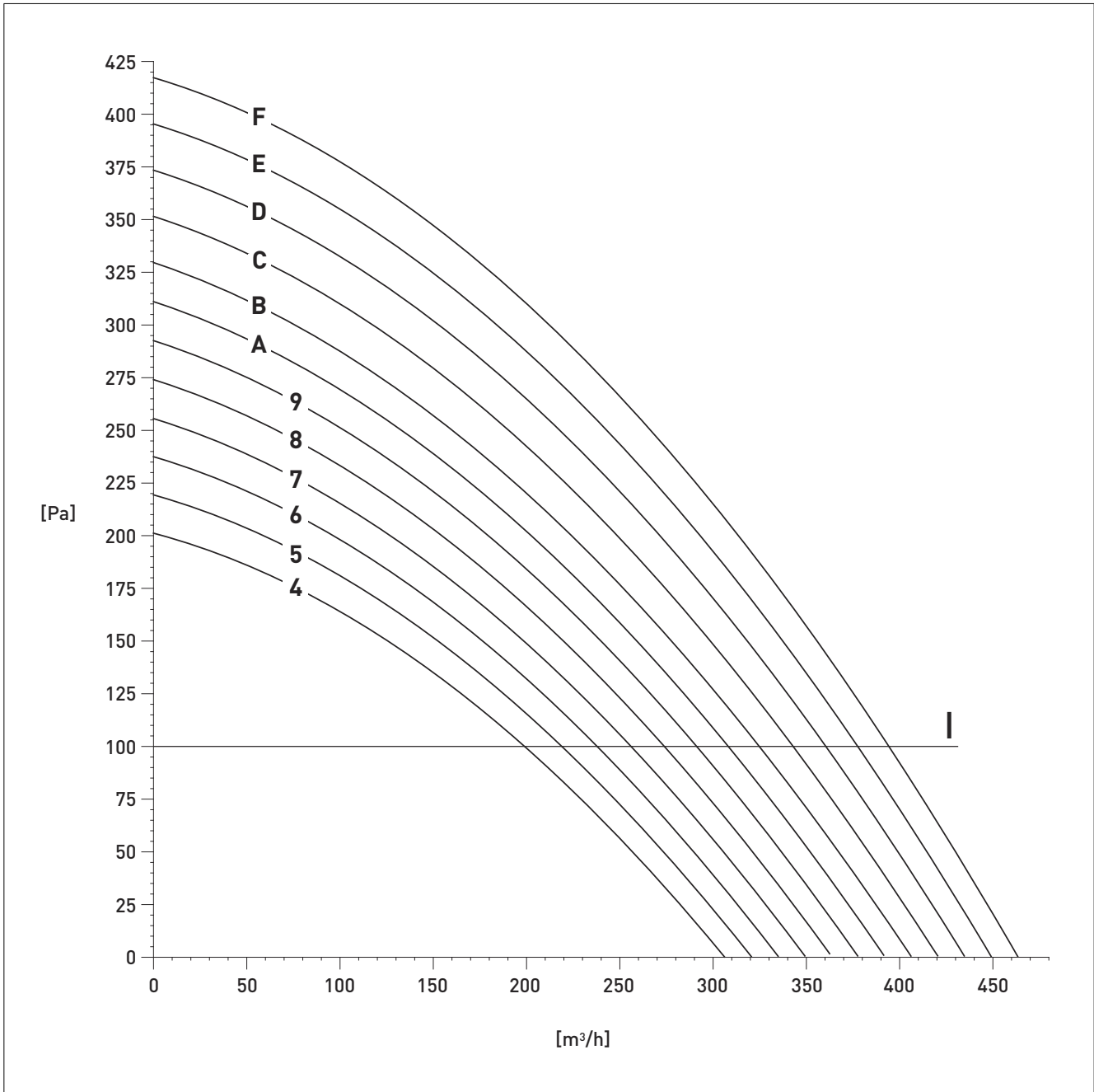

[Pa] Pressure loss

[m³/h] Nominal flow rate (extract air)

I Supposed system operating pressure

Adjustment flow rate

The ratio of flow rates between supply and extract air can be adjusted. The supply airflow rate is adapted on a percentage basis to the extract airflow rate at the potentiometer (28), see table below.

S&P recommends to balance both airflows as good as possible.

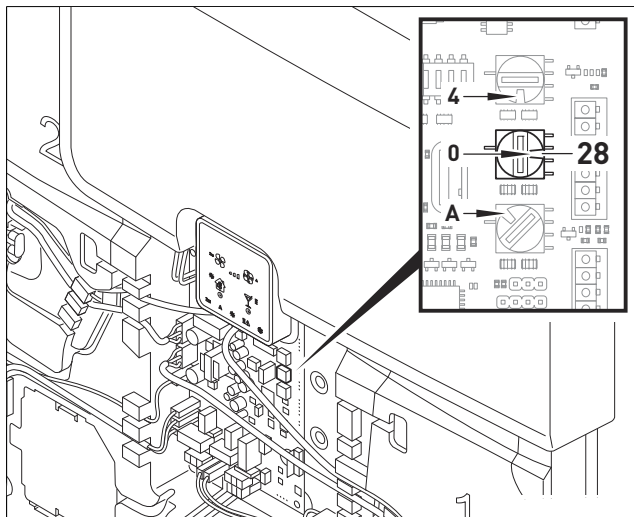

Set potentiometer (28) to the required ratio (factory setting Position 0).

Position potentiometer (28)	8	9	A	B	C	D	E	F	0	1	2	3	4	5	6	7
Ratio supply air/extract air	-32%	-28%	-24%	-20%	-16%	-12%	-8%	-4%	0	+4%	+8%	+12%	+16%	+20%	+24%	+28%



6.2.2. Adjusting nominal airflow rate (extract air) using differential pressure gauge

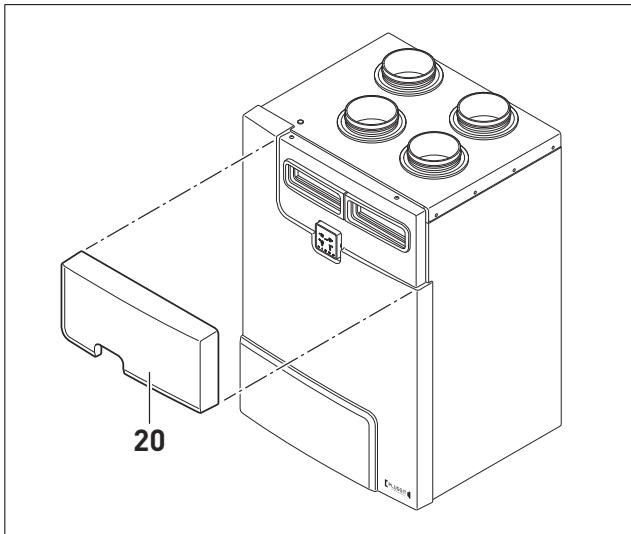

1. Remove filter cover (20).

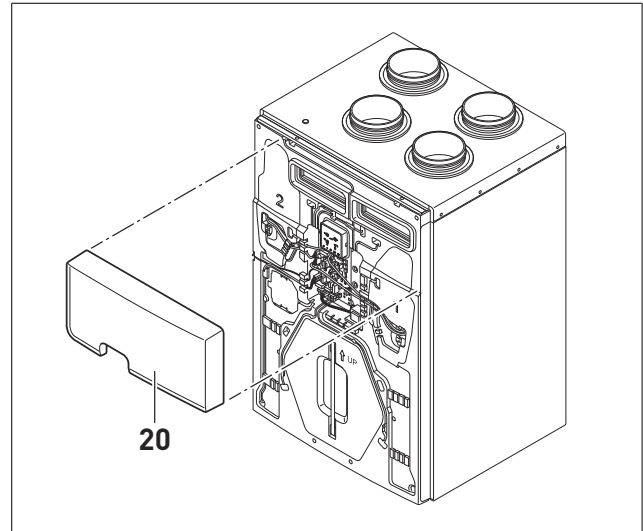

5. Reinsert filter cover (20).

NOTE

The first step is always to set the nominal airflow rate (extract air). To this end, check on the dip switch (5) which version is installed (Version A or Version B), see Set Version A or B, p. 10.

6. Set up power supply of the ventilation system.

7. Switch on fan speed V3 on the control panel, see Set fan speed by hand, p. 42.

NOTE

The values from the tables below refer to the setting of fan speed V3.

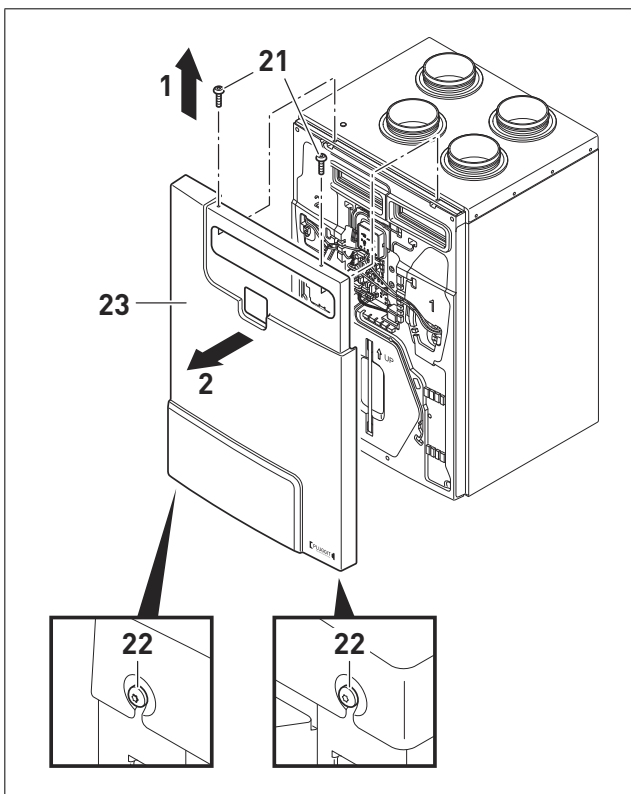

2. Loosen screws Torx 30 (22) on the bottom of the device.

3. Unscrew screws Torx 30 (21) on top of device (Arrow 1).

4. Remove front cover (23) (Arrow 2).

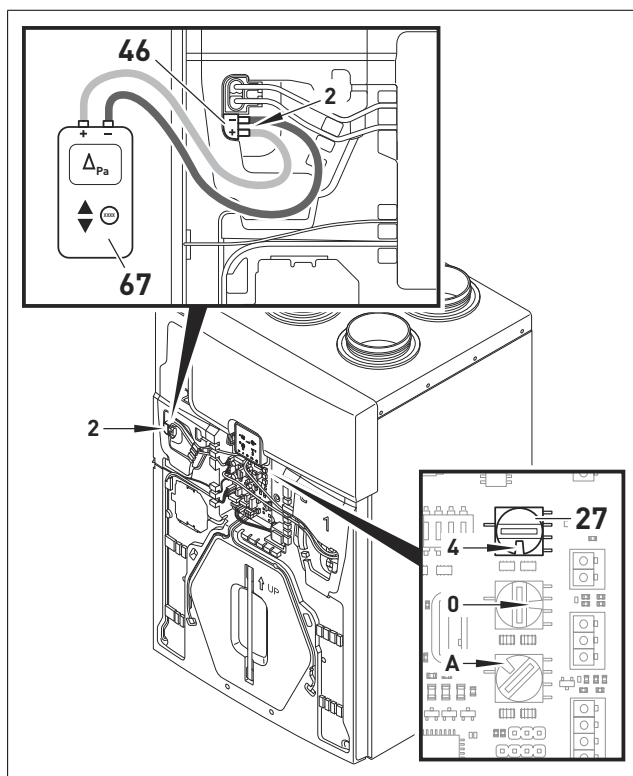

8. Take the cap off of the differential pressure taps (46).
9. Connect differential pressure gauge (67) to the differential pressure connecting piece 2 (46) and take a reading of the differential pressure [Pa]. Be careful with the correct connection of + and - (+/+ and -/-).
10. Turn potentiometer (27) until the desired differential pressure (= nominal airflow rate) is displayed on the differential pressure gauge (67).
Take the values for the ventilation system from the tables below.
11. Put the cap back on the original position closing the differential pressure taps (46).

Example for SABIK 350:

1. The nominal airflow rate (extract air) from the “suggested solution” is 170 m³/h.
2. Look for the value 170 in the table for SABIK 350:
3. Turn potentiometer (27) until 15-16 Pa is displayed on the differential pressure gauge (67).

SABIK 210

Version A			With pre heater
Airflow [m ³ /h]	Fan 2 (extract air) Pressure taps 2/ Potentiometer (27) [Pa]	Fan 1 (supply air) Pressure taps 1/ Potentiometer (28) [Pa]	Fan 1 (supply air) Pressure taps 1/ Potentiometer (28) [Pa]
80	7-8	9-12	17-18
90	9-10	13-15	21-22
100	11-13	16-19	26-27
110	14-15	20-23	32-33
120	17-19	23-26	39-40
130	21-23	26-29	46-47
140	24-26	30-34	53-54
150	28-29	35-38	60-61
160	32-33	40-41	71-72

SABIK 350

Version A			With pre heater
Airflow [m ³ /h]	Fan 2 (extract air) Pressure taps 2/ Potentiometer (27) [Pa]	Fan 1 (supply air) Pressure taps 1/ Potentiometer (28) [Pa]	Fan 1 (supply air) Pressure taps 1/ Potentiometer (28) [Pa]
140	10-11	17-19	22
150	12-13	20-21	25
160	14-15	22-23	29
170	15-16	24-25	32
180	17-18	27-29	38
190	19-20	30-32	41
200	21-22	34-36	45
210	23-24	37-38	49
220	25-26	40-42	56
230	28-29	44-46	67
240	31-32	48-50	73
250	34-35	51-52	77

SABIK 500

Version A			With pre heater
Airflow [m ³ /h]	Fan 2 (extract air) Pressure taps 2/ Potentiometer [27] [Pa]	Fan 1 (supply air) Pressure taps 1/ Potentiometer [28] [Pa]	Fan 1 (supply air) Pressure taps 1/ Potentiometer [28] [Pa]
230	18-20	22-23	20
240	21-23	25-26	23
250	23-24	27-28	25
260	24-26	29-30	27
270	26-27	32-33	28
280	28-29	34-35	30
290	31-32	37-38	32
300	32-34	39-42	34
310	35-36	43-44	36
320	37-39	45-46	39
330	40-41	48-50	42
340	42-43	51-53	44
350	44-45	54-56	47
360	46-48	57-58	50
370	49-50	59-60	53
380	51-52	61-62	56

Adjust supply airflow rate

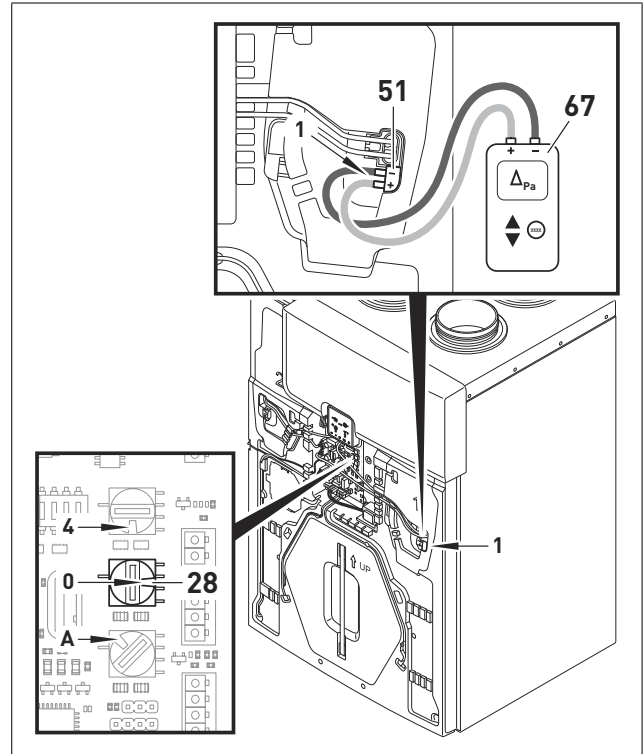

1. Take the cap off the differential pressure connecting piece 1 [51].
2. Connect differential pressure gauge (67) to the differential pressure connecting piece 1 [51] and take a reading of the differential pressure [Pa]. Be careful with the correct connection of + and - (+/+ and -/-).
3. Take the supply airflow rate from the "suggested solution."
4. Turn potentiometer (28) until the desired differential pressure is displayed on the differential pressure gauge (67).
Take the values for the ventilation system from the tables below.
5. Put the cap back on the original position closing the differential pressure taps [51].

Example for SABIK 350:

1. The supply airflow rate from the "suggested solution" is 170 m³/h.
2. Look for the value 170 in the table for SABIK 350.
3. Turn potentiometer (28) until 24-25 Pa is displayed on the differential pressure gauge (67).

SABIK 210

Version B			With pre heater
Airflow [m³/h]	Fan 1 (extract air) Pressure taps 1/ Potentiometer (28) [Pa]	Fan 2 (supply air) Pressure taps 2/ Potentiometer (27) [Pa]	Fan 2 (supply air) Pressure taps 2/ Potentiometer (27) [Pa]
80	9-10	7-8	12-13
90	11-12	9-10	15-16
100	14-15	11-12	19-20
110	18-19	14-15	24-25
120	21-22	18-19	27-28
130	24-25	21-22	32-33
140	29-30	24-25	37-38
150	33-34	28-29	43-44
160	38-39	33-34	48-49

SABIK 500

Version B			With pre heater
Airflow [m³/h]	Fan 1 (extract air) Pressure taps 1/ Potentiometer (28) [Pa]	Fan 2 (supply air) Pressure taps 2/ Potentiometer (27) [Pa]	Fan 2 (supply air) Pressure taps 2/ Potentiometer (27) [Pa]
230	21-22	20-21	20-21
240	25-26	21-22	22-23
250	27-28	23-24	24-25
260	29-30	25-26	26-27
270	32-33	27-28	28-29
280	34-35	29-30	30-31
290	37-38	31-32	33-34
300	39-40	34-35	35-36
310	43-44	36-37	37-38
320	47-48	38-39	39-40
330	50-51	41-42	42-43
340	53-54	44-45	44-45
350	56-57	46-47	47-48
360	58-59	48-50	49-50
370	60-61	51-52	51-52
380	62-63	53-54	53-54

SABIK 350

Version B			With pre heater
Airflow [m³/h]	Fan 1 (extract air) Pressure taps 1/ Potentiometer (28) [Pa]	Fan 2 (supply air) Pressure taps 2/ Potentiometer (27) [Pa]	Fan 2 (supply air) Pressure taps 2/ Potentiometer (27) [Pa]
140	14-15	11-12	17
150	17-18	13-14	20
160	19-20	15-16	22
170	25-26	16-17	25
180	28-29	19-20	27
190	32-33	21-22	31
200	34-35	22-23	34
210	37-38	25-26	38
220	41-42	27-28	42
230	46-47	29-30	47
240	49-50	32-33	53
250	51-52	35-36	56

6.3. ENABLING/DISABLING HUMIDITY SENSOR FOR AUTOMATIC MODE

In the automatic mode, the ventilation system regulates the speed using the value set for relative humidity in the extract air. For this purpose, the humidity sensor must be activated.

Factory setting: "on" = activated

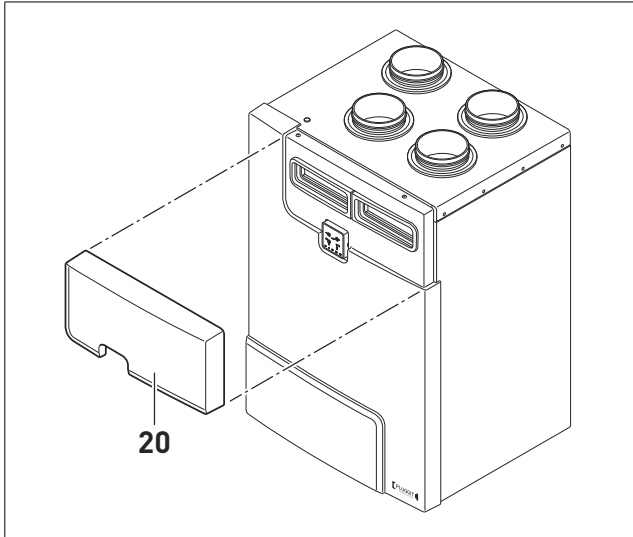

1. Disconnect power supply from ventilation system.
2. Remove filter cover [20].

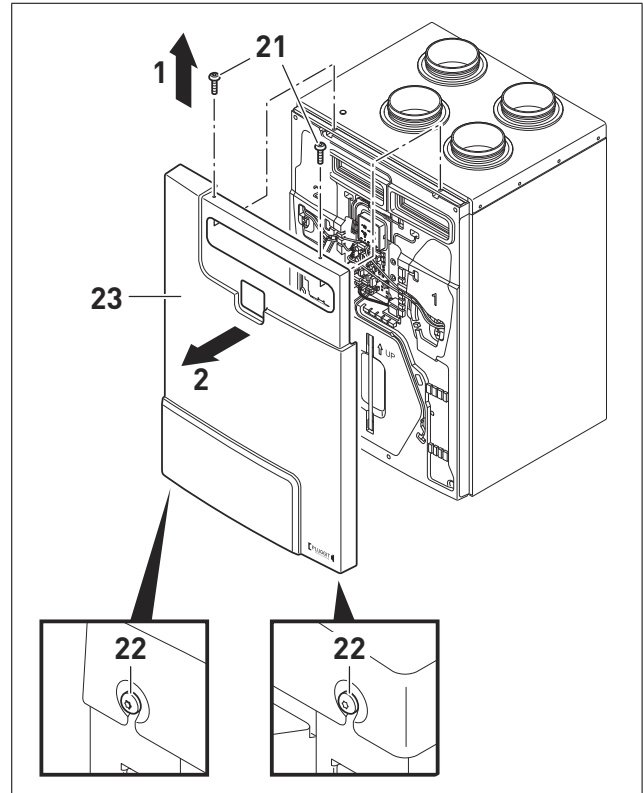

3. Loosen screws Torx 30 [22] on the bottom of the device.
4. Unscrew screws Torx 30 [21] on top of device (Arrow 1).
5. Remove front cover [23] (Arrow 2).

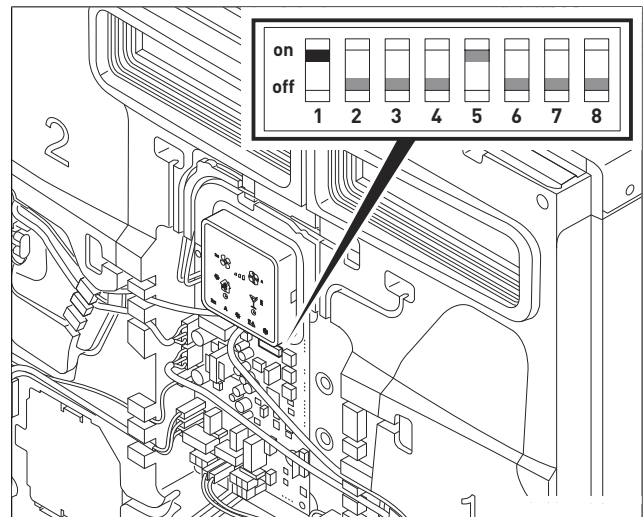

6. Enable:
Set dip switch 1 to "on."
The humidity sensor feature is activated.
- Disable:
Set dip switch 1 to "off."

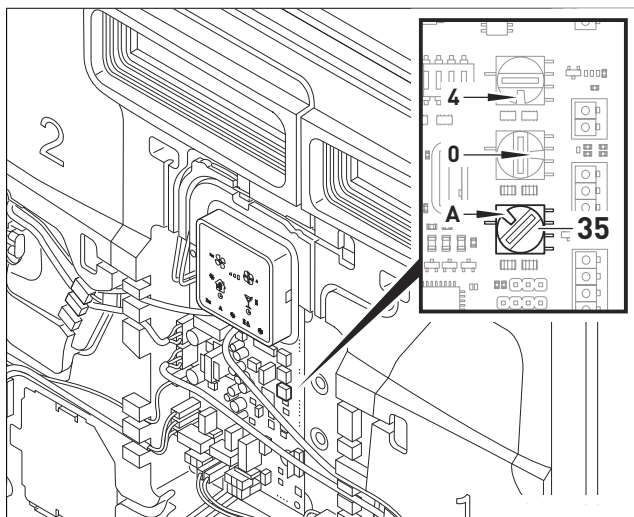

7. Position potentiometer (35) to the intended target extract air humidity, see the table below (factory setting Position A).

The upper target value for extract air humidity can be set between 60-90% using the potentiometer (35) (factory setting 80%, Position A).

The lower target value is permanently set to 45%. Within the range set, the system adjusts continuously. If the system falls short of the lower target value, then the system runs in the humidity protection mode. If the system exceeds the upper target value, then the system runs with nominal air.

Extract air humidity (%)		Position potentiometer (35)
60		0
62		1
64		2
66		3
68		4
70		5
72		6
74		7
76		8
78		9
80		A (Factory setting)
82		B
84		C
86		D
88		E
90		F

8. Screw on front cover (23) firmly with screws Torx 30 (21) and (22).

9. Insert filter cover (20).

10. Set up power supply of the ventilation system.

11. In order to set the ventilation system to the humidity-controlled mode, keep symbol pressed for 5 seconds.

When the automatic mode (humidity control) is activated, the A symbol lights up below on the control panel.

6.4. ENABLING/DISABLING VOC SENSOR (OPTIONAL ACCESSORY) FOR AUTOMATIC MODE

In automatic mode, the ventilation system regulates proportionally the speed in dependence of the concentration of pollutants measured in the extract air. For this purpose, a VOC sensor SABIK-VOC (optional accessory) must be installed, see separate operating and installation instructions.

The VOC target value is set using the potentiometer (35). The upper working range can be set between 1100-2000. The lower threshold value of 450 ppm is permanently programmed. The upper target value has been pre-set to 1700 ppm at the factory.

If the upper threshold value is exceeded, then the ventilation system runs with nominal air. If the system falls short of the lower threshold value, then the system runs in the humidity protection mode.

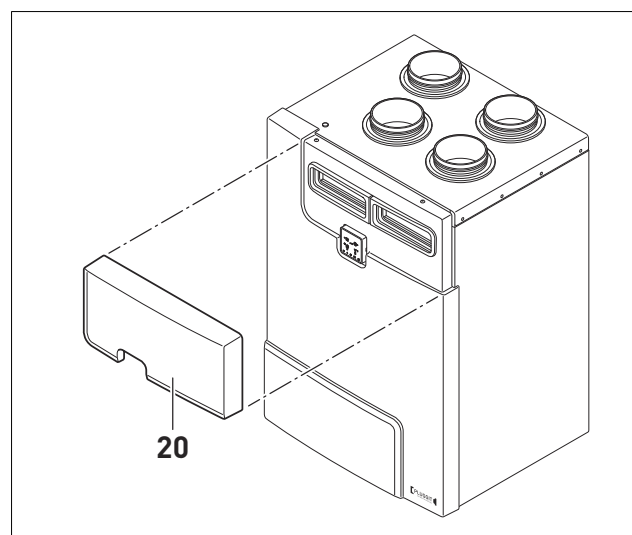

1. Disconnect power supply from ventilation system.

2. Remove filter cover (20).

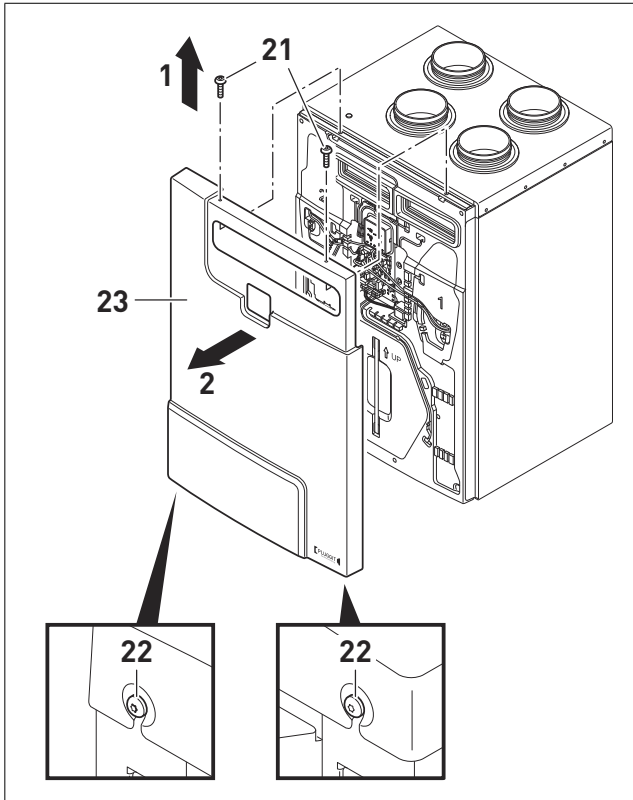

3. Loosen screws Torx 30 (22) on the bottom of the device.
4. Unscrew screws Torx 30 (21) on top of device (Arrow 1).
5. Remove front cover (23) (Arrow 2).

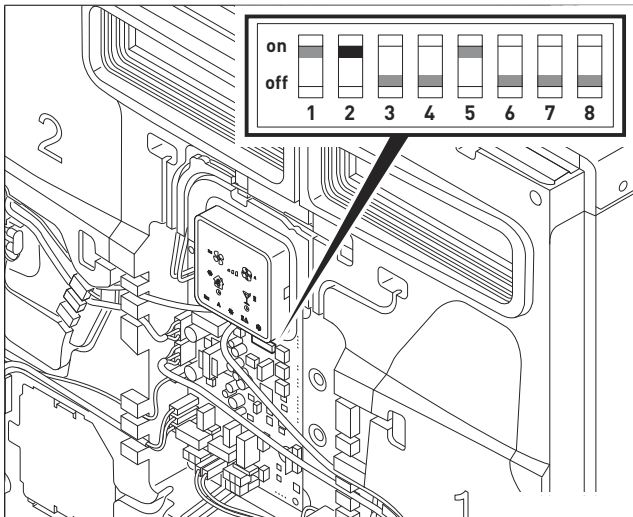

6. Enable:
Set dip switch **2** to "on."
The VOC sensor feature is activated.
- Disable:
Set dip switch **2** to "off."

NOTE

If several modes are activated, then the mode with the highest priority is carried out. Position of the potentiometer (35) is always identical for both functions, humidity and VOC.

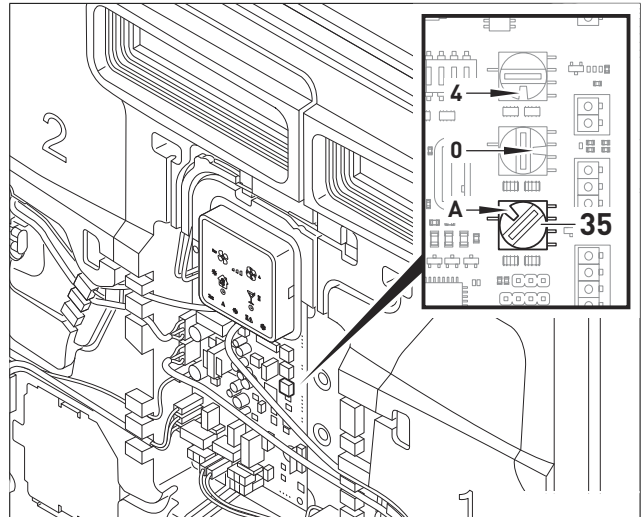

7. Adjust the potentiometer (35) according to the target value of the maximum concentration of pollutants in the extract air, see the following table (factory setting Position A).

Pollutant concentration (VOC) (ppm)		Position potentiometer (35)
1100	Lower pollutant concentration ↑ ↓ Higher pollutant concentration	0
1160		1
1220		2
1280		3
1340		4
1400		5
1460		6
1520		7
1580		8
1640		9
1700	A	(Factory setting)
1760		B
1820		C
1880		D
1940		E
2000		F

8. Screw on front cover (23) firmly with screws Torx 30 (21) and (22).
9. Insert filter cover (20).
10. Set up power supply of the ventilation system.
11.  In order to set the ventilation system to the VOC-controlled mode, keep symbol depressed for five seconds. When the automatic mode (VOC-controlled mode) is activated, the A symbol below on the control panel lights up.

6.5. ENABLING/DISABLING EXTERNAL INPUT 0-10 V

6.5.1. General information

In automatic mode, the air volume in the ventilation system is regulated by an external 0-10 V signal. The input signal 0 V corresponds to the humidity protection flow rate. The input signal 10 V corresponds to the nominal airflow rate.

6.5.2. Activate 0-10 V input through external sensors (Airsens RF-RH/CO2)

You can find more detailed information on the REC.Airsens receiver and the Airsens sensors in the operating instructions, which are enclosed separately.

Operation

The REC.Airsens receiver is equipped with an analogue signal output. Operating modes can be combined.

Analogue signal output (0-10 V signal)

The REC.Airsens receiver replicates the 0-10 V output signal of the connected Airsens senders when the latter are running in operating modes MF2 or MF3. If several senders are connected, then the highest 0-10 V signal is transmitted as target value.

You can find out more about the different operating modes in the operating instructions for the Airsens sensors.

Connecting REC.Airsens receiver

1. Install REC.Airsens receiver in a dry environment (IP20) on a flat surface using the four mounting points.
2. Loosen screws, press both flaps inward with an appropriate tool and remove the cover.

Connect REC.Airsens with the ventilation unit

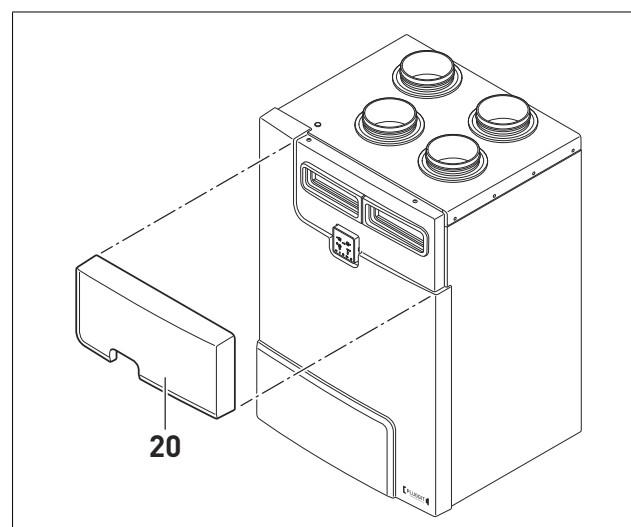

1. Disconnect power supply from ventilation system.
2. Remove filter cover (20).

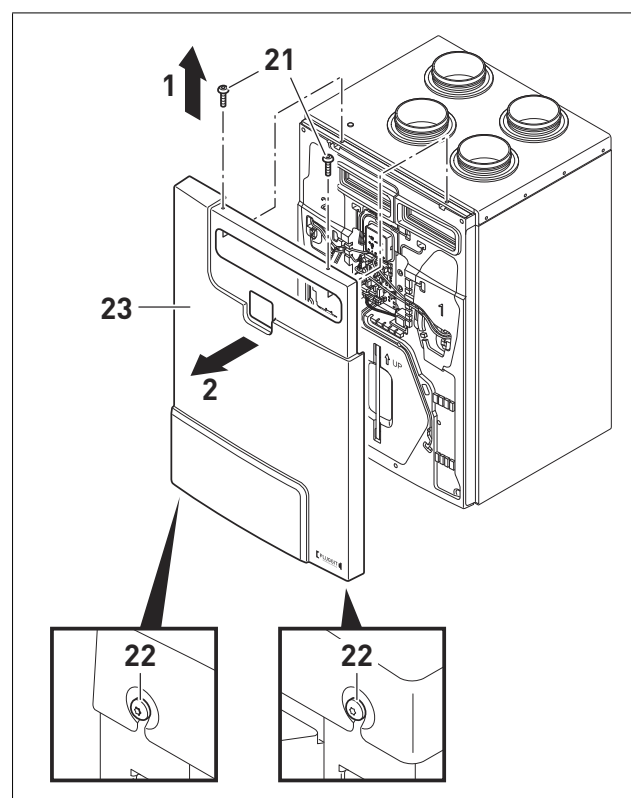

3. Loosen screws Torx 30 (22) on the bottom of the device.
4. Unscrew screws Torx 30 (21) on top of device (Arrow 1).
5. Remove front cover (23) (Arrow 2).

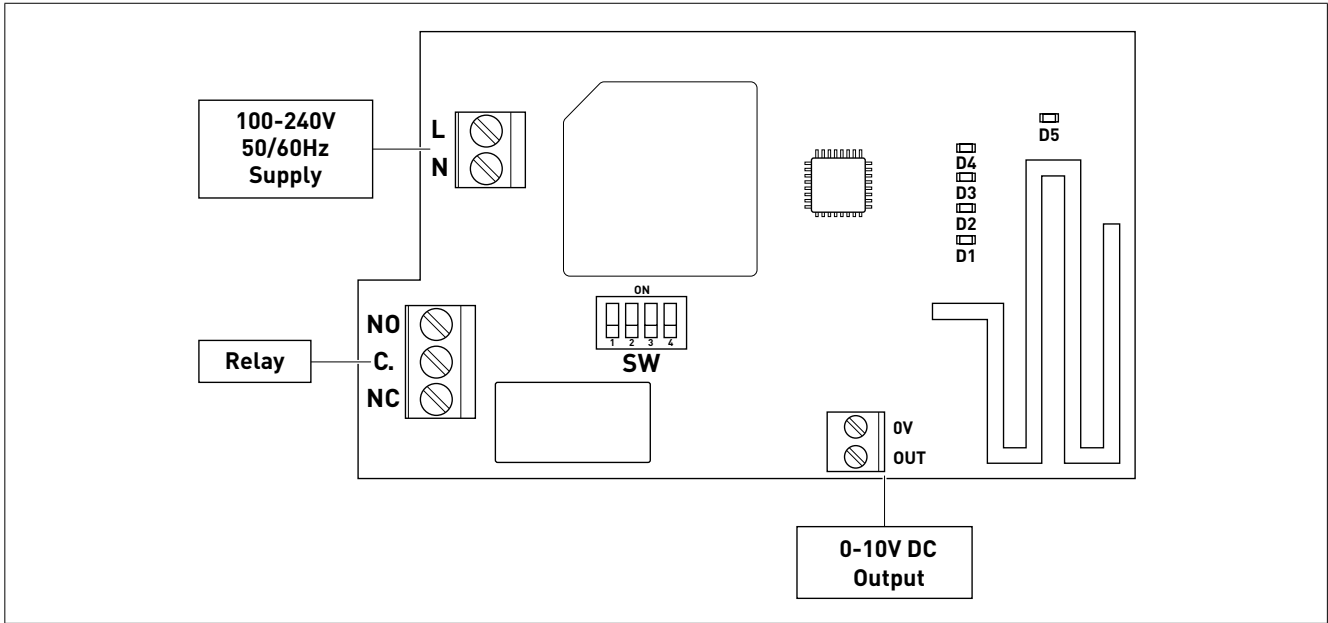

6. Set up connections to REC.Airsens receiver.

Connect Airsens RF-RH/CO2 sensors

1. Install Airsens RF-RH/CO2 sensors in a dry environment (IP30) on a flat surface using the four mounting points.

NOTE

The recommended height for installation is 1.5-1.8 m. Make sure that the environmental conditions at the installation site do not influence the measurement. For example, influences such as direct sunlight, proximity to air currents from windows, doors or other ventilation systems must be avoided.

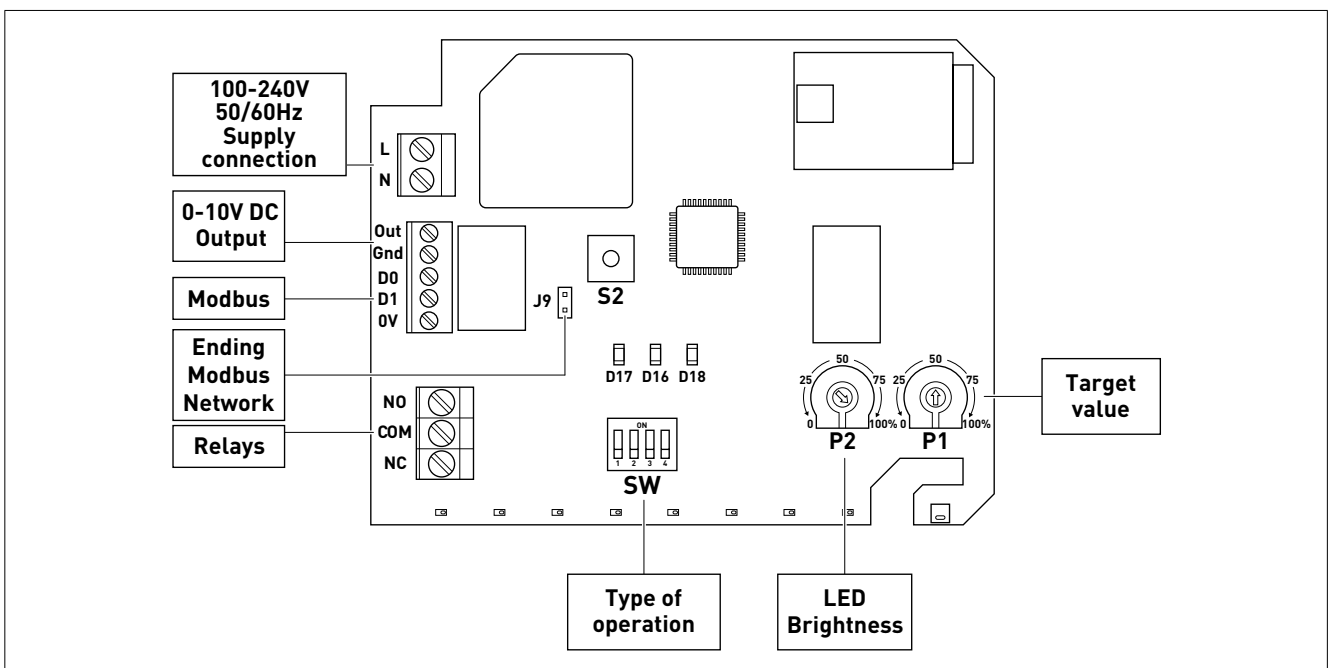

2. Connect to the Airsens RF-RH/CO2 sensors.

Connect the REC.Airsens receiver with the Airsens sensors

1. Connect the REC.Airsens receiver to the power supply. The device is switched on. Then, it begins to establish a connection automatically with the Airsens senders (max. 4 items). When pairing, a bi-color D5-LED flashes on the receiver and when this period expires (about 2 minutes), a fixed green light appears. If pairing to the senders was not successful, then repeat the procedure.
2. Press button S2 on each Airsens sender to be connected, see p. 31. When pairing is successful, one of the D1-D4-LEDs on the receiver will illuminate on fixed green. One of the LEDs must light up for each Airsens sender. For more information, see Airsens operating instructions.

Operating modes

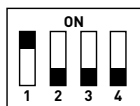

Operating mode MF2
0-10 V DC
Output + Modbus (read)

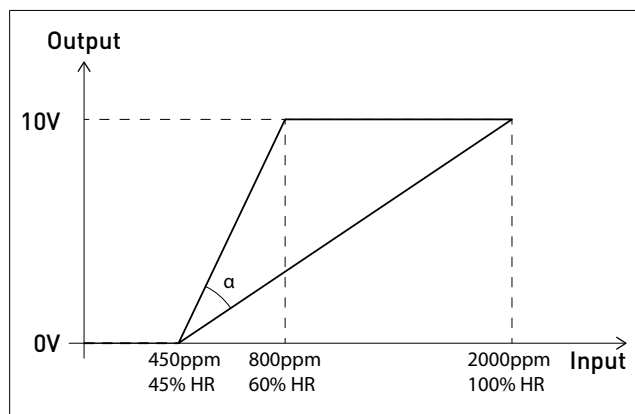

α Ramp can be adjusted using potentiometer P1

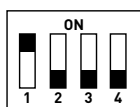

Operating mode MF3
2-10 V DC
Output + Modbus (read)

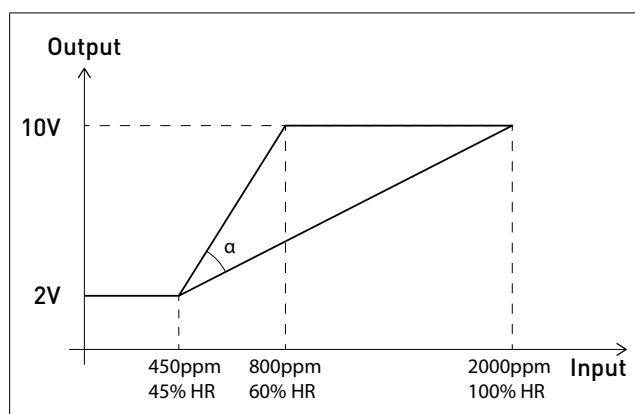

α Ramp can be adjusted using potentiometer P1

Position potentiometer	Operating modes MF2/MF3: Upper	
	(%)	(HR)
0	800	60
5	860	62
10	920	64
15	980	66
20	1040	68
25	1100	70
30	1160	72
35	1220	74
40	1280	76
45	1340	78
50	1400	80
55	1460	82
60	1520	84
65	1580	86
70	1640	88
75	1700	90
80	1760	92
85	1820	94
90	1880	96
95	1940	98
100	2000	100

6.6. ENABLING/DISABLING FIREPLACE MODE

To avoid the back-flow of gases into the room from the open flue of gas or other fuel-burning appliances, the fireplace mode must be activated. When activating, S&P recommends that you also install a pre-heater SABIK 210-HR / SABIK 350-HR / SABIK 500-HR (optional accessory) in order to ensure continuous operation of the device.

If there is risk of freezing, then the ventilation system is shut down through the fireplace mode for 2 hours. When this time has elapsed, the device switches itself on and checks the conditions. If the conditions have not changed, the device shuts down again for 2 hours. This cycle repeats itself until conditions for continuous operation have been re-established.

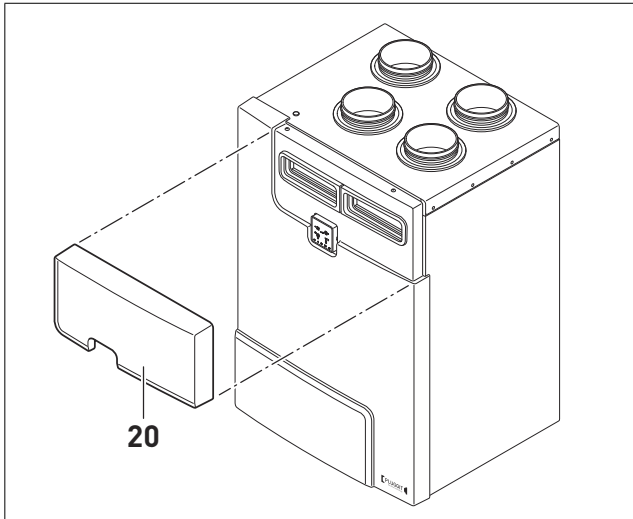

1. Disconnect power supply from ventilation system.
2. Remove filter cover [20].

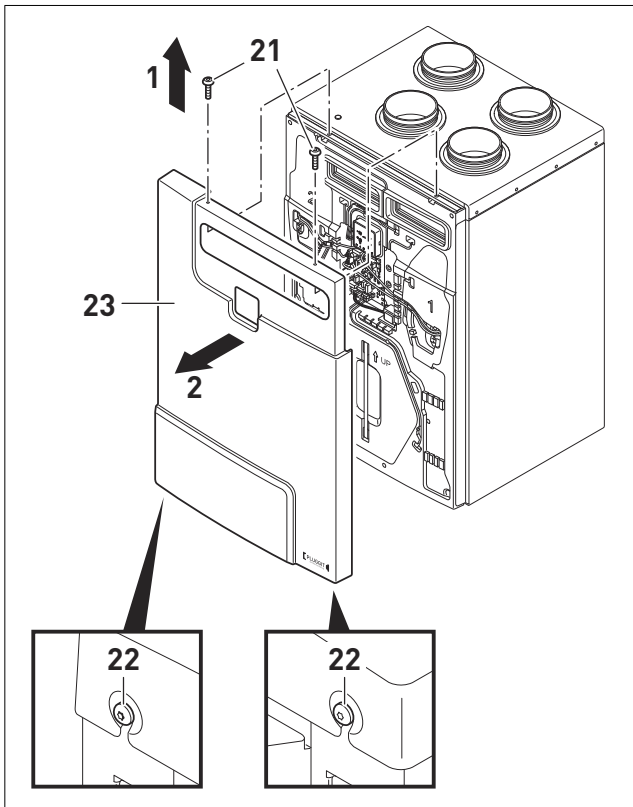

3. Loosen screws Torx 30 [22] on the bottom of the device.
4. Unscrew screws Torx 30 [21] on top of device (Arrow 1).
5. Remove front cover [23] (Arrow 2).

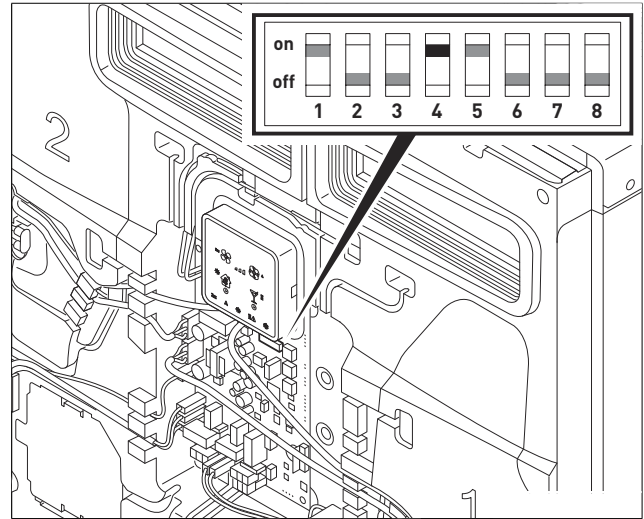

6. Enable:
Set dip switch **4** to "on."
The fireplace mode is activated.
- Disable:
Set dip switch **4** to "off."
7. Screw on front cover [23] firmly with screws Torx 30 [21] and [22].
8. Insert filter cover [20].
9. Set up power supply of the ventilation system.

6.7. ENABLING/DISABLING EMERGENCY SHUTDOWN CONTACT

This contact can be used to shut down the ventilation system in an emergency case.

NOTE

As soon the system has been triggered using this contact, the units has to be reseted disconnecting the unit from the power supply.

The switching function that must be set must be adapted to the components to be connected (normally open contact/normally closed contact). The contact is set using the dip switch 6, as follows.

Factory setting: "off" = normally open contact

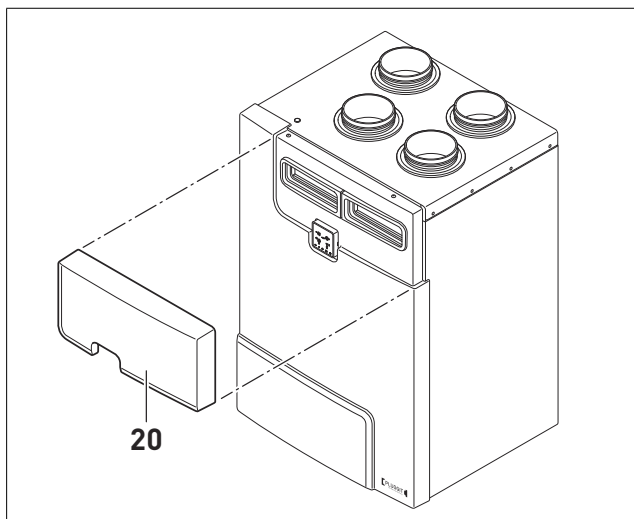

1. Disconnect power supply from ventilation system.
2. Remove filter cover (20).

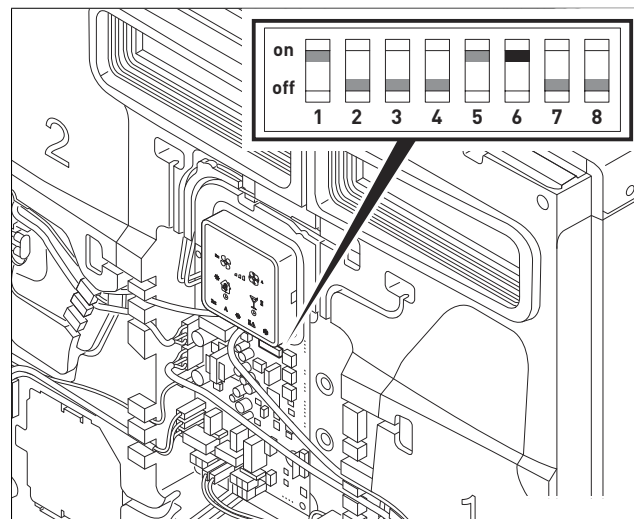

6. Enable:
Reset dip switch 6 to "on" = normally closed contact.
- Disable:
Reset dip switch 6 to "off" = normally open contact.

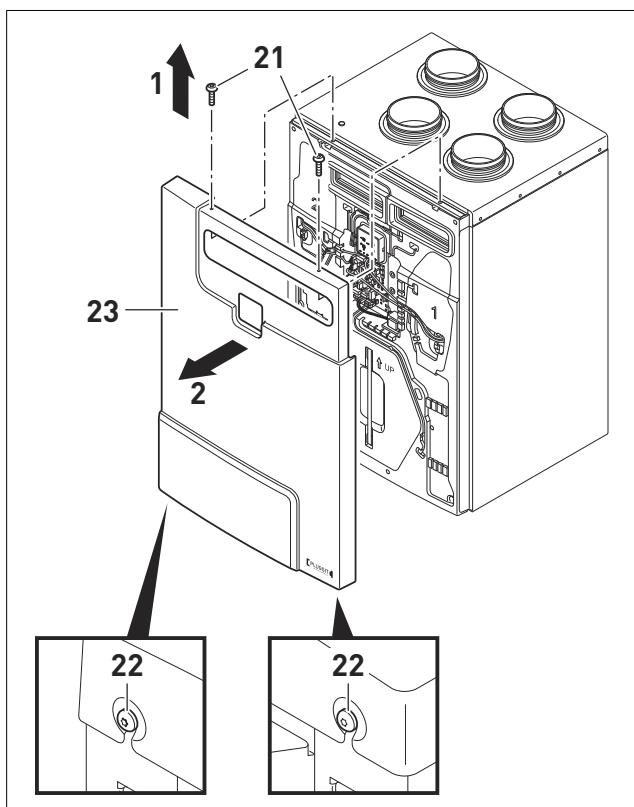

3. Loosen screws Torx 30 (22) on the bottom of the device.
4. Unscrew screws Torx 30 (21) on top of device (Arrow 1).
5. Remove front cover (23) (Arrow 2).

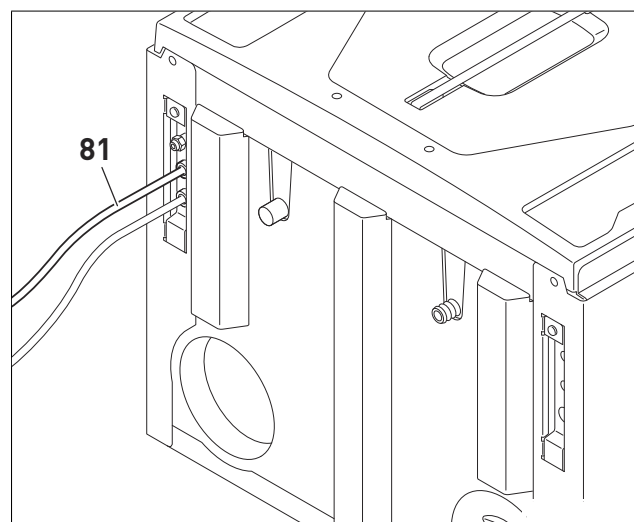

7. Conduct cables (81) of the components to be connected (smoke alarm, pressure switch, etc.) to the ventilation system by feeding them through.

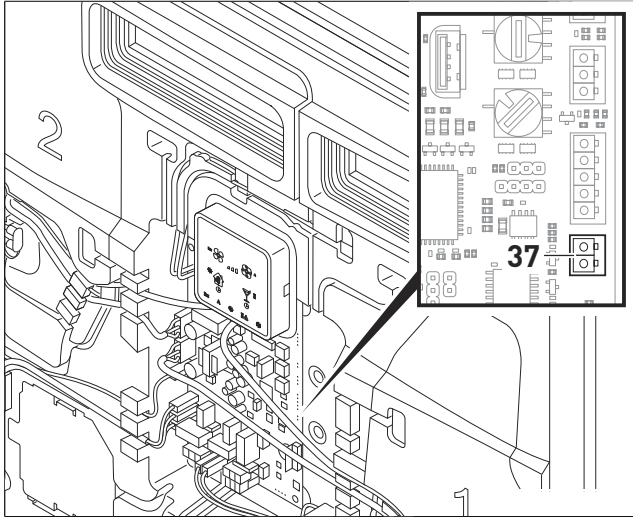

8. Attach cables of the components to the connection (37).
9. Screw on front cover (23) firmly with screws Torx 30 (21) and (22).
10. Insert filter cover (20).
11. Set up power supply of the ventilation system.

6.8. ENABLING/DISABLING BOOST FAN SPEED

This contact can be used for activating the fan speed BOOST (intensive ventilation) using an external switch. You can use dip switch 7 to set whether the contact functions as normally open contact or normally closed contact.

Factory setting: "off" = normally open contact

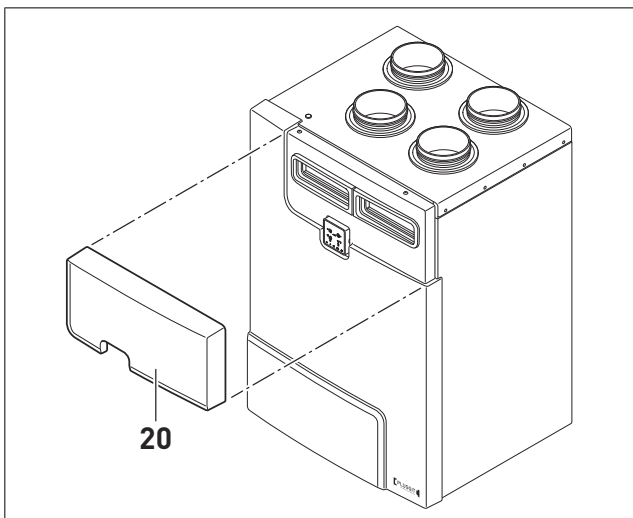

1. Disconnect power supply from ventilation system.
2. Remove filter cover (20).

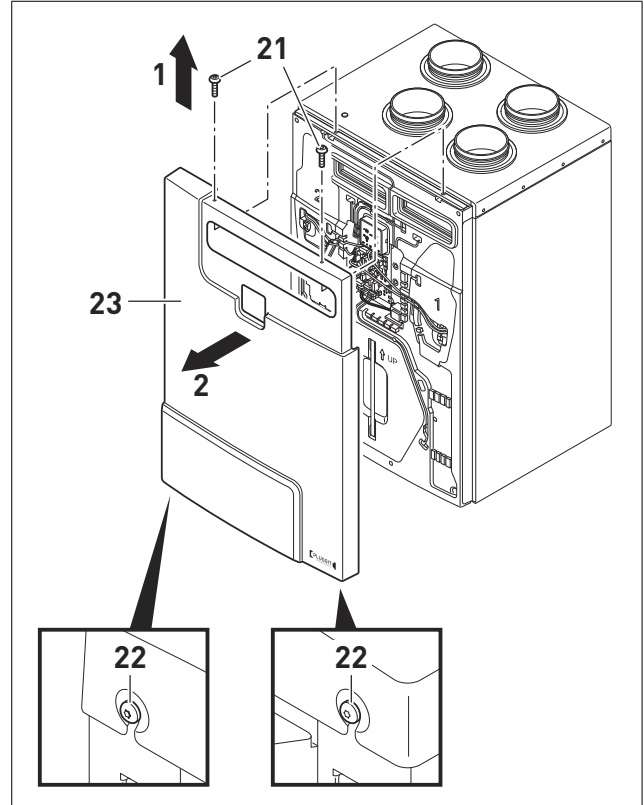

3. Loosen screws Torx 30 (22) on the bottom of the device.
4. Unscrew screws Torx 30 (21) on top of device (Arrow 1).
5. Remove front cover (23) (Arrow 2).

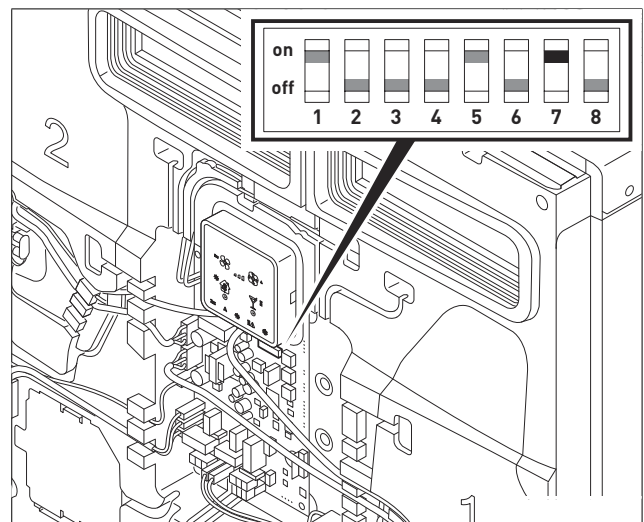

6. Enable:
Reset dip switch **7** to "on" = normally closed contact.
- Disable:
Reset dip switch **7** to "off" = normally open contact.

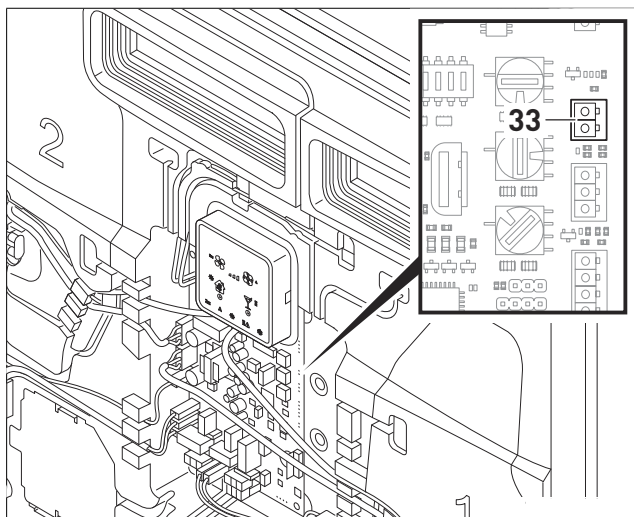

7. Connect switch at connection point (33).
8. Screw on front cover (23) firmly with screws Torx 30 (21) and (22).
9. Insert filter cover (20).
10. Set up power supply of the ventilation system.

6.9. ENABLING/DISABLING WEEKLY PROGRAMME

In automatic mode the ventilation system regulates the speed using the weekly programme that has been set, see Setting weekly programme, p. 38.

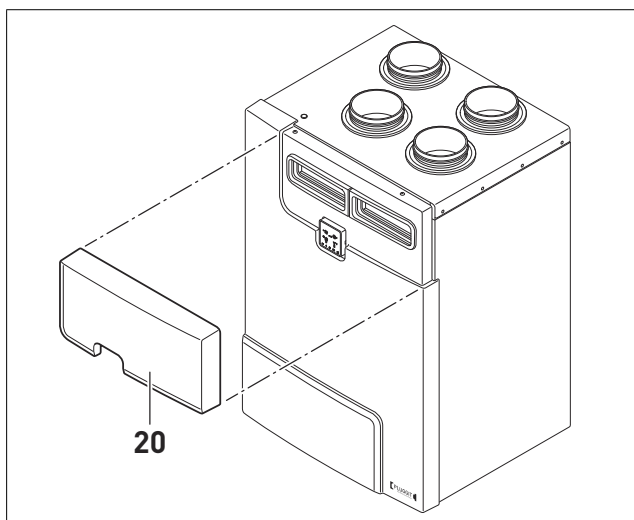

1. Disconnect power supply from ventilation system.
2. Remove filter cover (20).

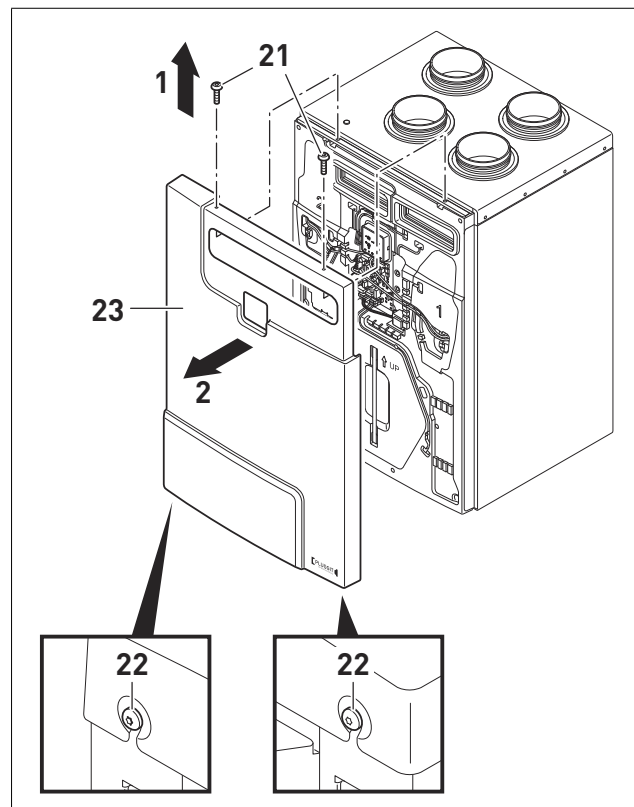

3. Loosen screws Torx 30 (22) on the bottom of the device.
4. Unscrew screws Torx 30 (21) on top of device (Arrow 1).
5. Remove front cover (23) (Arrow 2).

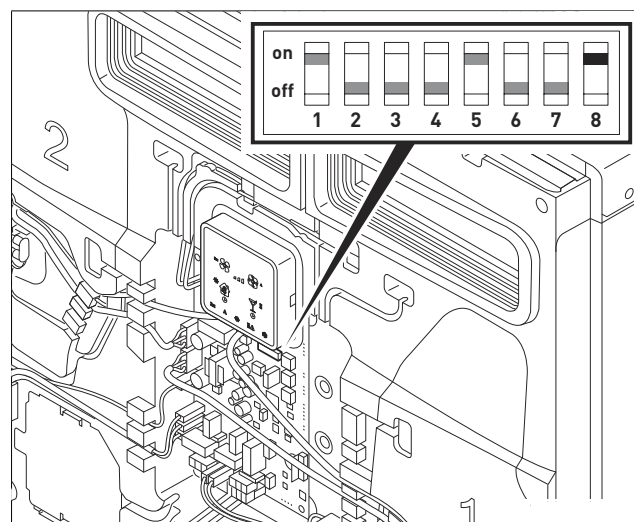

6. Enable:
Set dip switch **8** to "on."
- Disable:
Set dip switch **8** to "off."

NOTE

When using the weekly programme 3, see Weekly programme 3, p. 40, one of the sensors must be activated:

- Set humidity sensor (integrated as standard) = dip switch 1 to "on."
- Set VOC sensor (optional accessory) = dip switch 2 to "on."
- Set 0-10 V entrance (external signal) = dip switch 3 to "on."

7. Screw on front cover (23) firmly with screws Torx 30 (21) and (22).

8. Insert filter cover (20).

9. Set up power supply of the ventilation system.

10.  So that the ventilation system runs with the weekly programme that has been set, keep the symbol depressed for 5 seconds. When the automatic mode (weekly programme) is activated, the A symbol lights up below on the control panel.

7. INDIVIDUAL USER SETTINGS

7.1. SET TIMER FOR FILTER ALARM

The factory setting for the timer for the filter alarm is 12 months. Replacing of the filter is highly dependent on the pollution of the outdoor air (pollen count, construction site activity). The timer for the filter alarm can be set to 6 months, 9 months or 15 months.

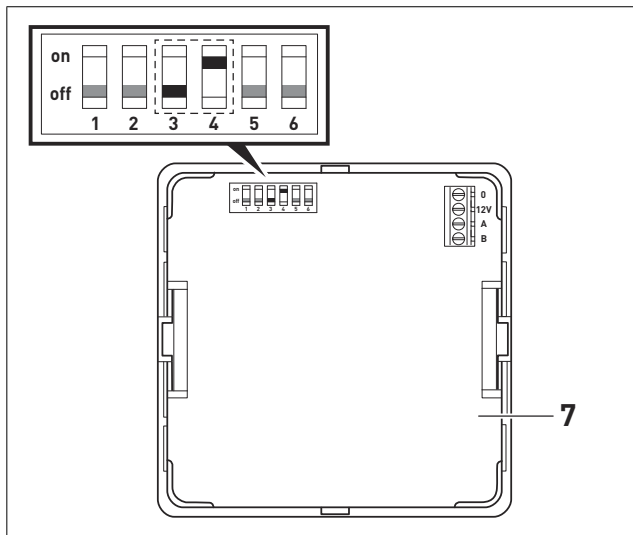

1. Remove back cover of control panel (7), see Connection control panel SABIK-FB, p. 16.

2. Set dip switches 3 and 4 to desired timer.

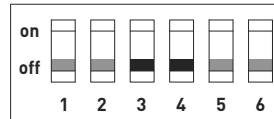

6 months

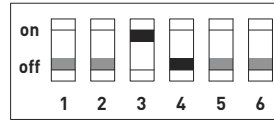

9 months

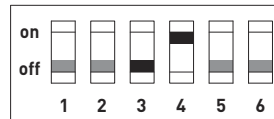

12 months
(Factory setting)

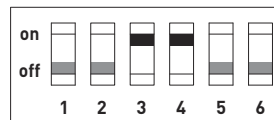

15 months

7.2. SETTING WEEKLY PROGRAMME

A weekly program for setting the fan speeds can be set using the dip switches on the back of the control panel. A total of four weekly programmes are available. The factory setting is weekly programme 1.

Regulation of the ventilation system using a weekly programme must be activated on the dip switch 8 on the main circuit board, see Enabling/Disabling weekly programme, p. 37.

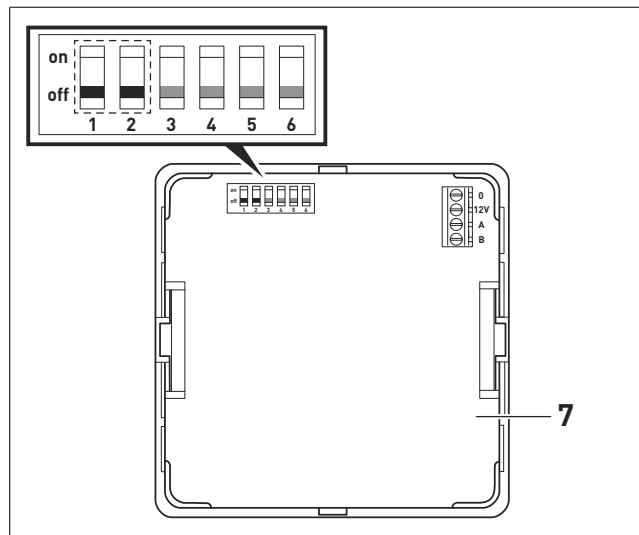

1. Remove back cover of control panel (7), see Connection control panel SABIK-FB, p. 16.

2. Set dip switches 1 and 2 to the desired weekly programme.

Weekly programme 1 (factory setting)

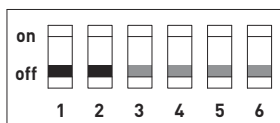

		Monday-Friday																							
Time / Speed	0	1	2	3	4	5	6	7	8	9	10	11	12	13	14	15	16	17	18	19	20	21	22	23	
	-	-	-	-	-	-	-	-	-	-	-	-	-	-	-	-	-	-	-	-	-	-	-	-	
	1	2	3	4	5	6	7	8	9	1	11	12	13	14	15	16	17	18	19	20	21	22	23	24	
4																									
3																									
2																									
1																									

		Saturday-Sunday																							
Time / Speed	0	1	2	3	4	5	6	7	8	9	10	11	12	13	14	15	16	17	18	19	20	21	22	23	
	-	-	-	-	-	-	-	-	-	-	-	-	-	-	-	-	-	-	-	-	-	-	-	-	
	1	2	3	4	5	6	7	8	9	1	11	12	13	14	15	16	17	18	19	20	21	22	23	24	
4																									
3																									
2																									
1																									

Weekly programme 2

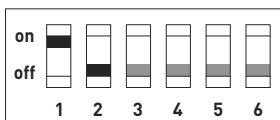

		Monday-Friday																							
Time / Speed	0	1	2	3	4	5	6	7	8	9	10	11	12	13	14	15	16	17	18	19	20	21	22	23	
	-	-	-	-	-	-	-	-	-	-	-	-	-	-	-	-	-	-	-	-	-	-	-	-	
	1	2	3	4	5	6	7	8	9	1	11	12	13	14	15	16	17	18	19	20	21	22	23	24	
4																									
3																									
2																									
1																									

		Saturday-Sunday																							
Time / Speed	0	1	2	3	4	5	6	7	8	9	10	11	12	13	14	15	16	17	18	19	20	21	22	23	
	-	-	-	-	-	-	-	-	-	-	-	-	-	-	-	-	-	-	-	-	-	-	-	-	
	1	2	3	4	5	6	7	8	9	1	11	12	13	14	15	16	17	18	19	20	21	22	23	24	
4																									
3																									
2																									
1																									



Weekly programme 3

NOTE

For Weekly Programme 3, one of the following sensors must be activated:

- Humidity sensor Enabling/Disabling humidity sensor for automatic mode.
- VOC sensor (optional accessory) Enabling/Disabling VOC sensor (optional accessory) for automatic mode.
- 0-10 V signal (optional accessory) Enabling/Disabling external entrance 0-10 V.

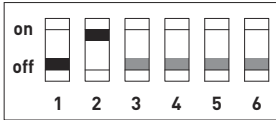

		Monday-Friday																								
Time / Speed	0	1	2	3	4	5	6	7	8	9	10	11	12	13	14	15	16	17	18	19	20	21	22	23	24	
	-	-	-	-	-	-	-	-	-	-	-	-	-	-	-	-	-	-	-	-	-	-	-	-	-	-
4																										
3							Sensor	Sensor	Sensor	Sensor	Sensor	Sensor	Sensor	Sensor	Sensor	Sensor	Sensor	Sensor	Sensor	Sensor	Sensor	Sensor				
2																										
1																										

		Saturday-Sunday																								
Time / Speed	0	1	2	3	4	5	6	7	8	9	10	11	12	13	14	15	16	17	18	19	20	21	22	23	24	
	-	-	-	-	-	-	-	-	-	-	-	-	-	-	-	-	-	-	-	-	-	-	-	-	-	-
4																										
3							Sensor	Sensor	Sensor	Sensor	Sensor	Sensor	Sensor	Sensor	Sensor	Sensor	Sensor	Sensor	Sensor	Sensor	Sensor	Sensor				
2																										
1																										

Weekly programme 4

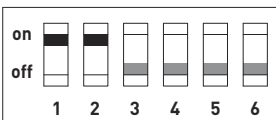

		Monday-Friday																								
Time / Speed	0	1	2	3	4	5	6	7	8	9	10	11	12	13	14	15	16	17	18	19	20	21	22	23	24	
	-	-	-	-	-	-	-	-	-	-	-	-	-	-	-	-	-	-	-	-	-	-	-	-	-	-
4																										
3																										
2																										
1																										

		Saturday-Sunday																								
Time / Speed	0	1	2	3	4	5	6	7	8	9	10	11	12	13	14	15	16	17	18	19	20	21	22	23	24	
	-	-	-	-	-	-	-	-	-	-	-	-	-	-	-	-	-	-	-	-	-	-	-	-	-	-
4																										
3																										
2																										
1																										

8. OPERATION (USERS)

8.1. CONTROL PANEL SABIK-FB

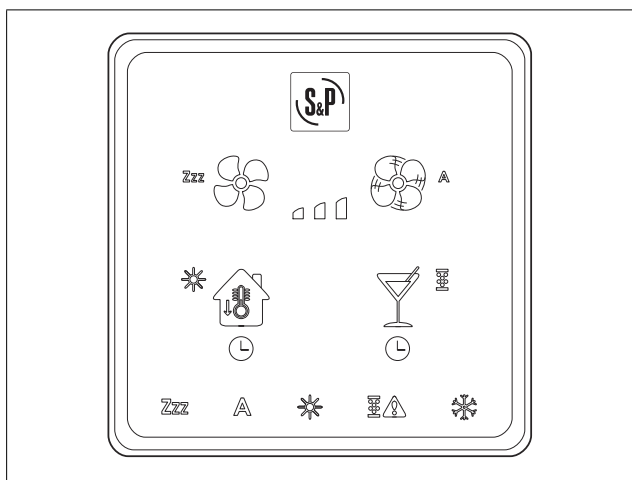

	Touch for 1 second			
			Boost speed	
			Summer bypass active for 8 hours	
	Touch for 5 seconds		Ventilation system stops for 1 hour	
			In automatic mode, the ventilation system is regulated using an activated sensor or an activated weekly programme.	
			Reset filter alarm	
			Summer mode activated	
			Anti-freeze activated	



8.2. SET FAN SPEED BY HAND

The fan speeds can be lowered or raised by hand if needed. The number of LEDs illuminated corresponds to the fan speed set.

8.3. SWITCHING BOOST ON/OFF

The ventilation system can be turned on to the fan speed BOOST, as needed, e.g., if many people are gathering in the house.

8.4. TURN ON/OFF SUMMER BYPASS

The summer bypass serves to bypass the heat exchanger so that the cooler outdoor air is not heated. When outdoor temperatures are lower, e.g. in spring or fall, the ventilation system can be used without heat recovery so that the cooler outdoor air is conducted into the building. The summer bypass can be activated for 8 hours by hand. Then the system switches to the fan speed most recently selected or to the weekly programme set, see Setting weekly programme, p. 38.

The following conditions have to be fulfilled to open/close the bypass automatically:

Activation conditions:

(Outdoor temperature $> 13^{\circ}\text{C}$) & (Indoor temperature $> 23^{\circ}\text{C}$) & (Indoor temp. – Outdoor temp. $> 3^{\circ}\text{C}$)

Deactivation conditions:

(Outdoor temperature $\leq 13^{\circ}\text{C}$) or (Indoor temperature $\leq 23^{\circ}\text{C}$) or (Indoor temp. – Outdoor temp. $\leq 3^{\circ}\text{C}$)

8.5. SWITCHING SLEEP MODE ON/OFF

When the sleep mode is activated, the ventilation system shuts off for one hour.

Then the system switches to the fan speed most recently selected or to the weekly programme set, see Setting weekly programme, p. 38.

8.6. TURN AUTOMATIC MODE ON/OFF

Once the automatic mode has been activated, the ventilation system can be controlled using one of the following options:

- Control of sensor
 - Activated humidity sensor, see Enabling/Disabling humidity sensor for automatic mode, p. 28,
 - Activated VOC sensor (optional accessory), see Enabling/Disabling VOC sensor (optional accessory) for automatic mode, p. 29 or
 - Activated 0-10 V signal (optional accessory), see Enabling/Disabling external entrance 0-10 V, p. 31.
- Weekly programme set, see Setting weekly programme, p. 38.
- Combination of sensor control and setting of weekly programme 3, see Setting weekly programme, p. 40.

NOTE

A combination with one sensor is only possible with the weekly programme 3.

8.7. RESET FILTER ALARM

After each time the filter is replaced, the filter alarm must be reset.

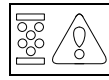

The symbol lights up when the pre-set timer for the filter replacement has been exceeded. The filters must be replaced, see Replacing filters, p. 47.

If the filter is not replaced within 60 days, then the ventilation system shuts down automatically.

NOTE

The factory setting for the timer for the filter alarm is 12 months. Replacing of the filter is highly dependent on the pollution of the outdoor air (pollen count, construction site activity). The timer for the filter alarm can be set to 6 months, 9 months or 15 months, see Set timer for filter alarm, p. 38.

8.8. SWITCH SUMMER MODE ON/OFF

When outdoor temperatures are cooler, e.g., at night, the supply air fan can be switched off. The outdoor air must then reach the house through open windows without heat recovery.

The summer mode can only be switched on when the outdoor air temperature is above $+13^{\circ}\text{C}$. If the outdoor air temperature drops below this value, then the summer mode is switched off again automatically.

After 2 hours, the temperatures are checked. For this purpose, the outside air fan starts up again for 5 minutes. If the outdoor temperature continues to exceed $+13^{\circ}\text{C}$, then the function continues until it is turned off by hand or until the temperature drops below $+13^{\circ}\text{C}$.

8.9. ANTI-FREEZE PROTECTION

Without installing an optional pre-heater module, the anti-freeze protection serves to protect the ventilation system from freezing. In this process, the supply air fan switches itself off.

If the fireplace mode has been enabled (see p. 33) and there is risk of freezing, then the ventilation system is shut down for 2 hours. When this time has elapsed, the device switches itself on and checks the conditions. If the conditions have not changed, the device shuts down again for 2 hours. This cycle repeats itself until conditions for continuous operation have been re-established.

9. REDUCED LIST OF MODBUS REGISTERS

SABIK device has a RS485 communication port located on position 32 in the main circuit board (see p. 9).

The Slave Address by default is 1, if few units are connected in the Modbus network, the address of each one must be different from the others. The communication parameters must be the same for all units connected on the same network. For more information regarding the communication parameters see the table of Holding Registers below:

DISCRETE INPUTS (Read only)					
Modbus Address	Register	Values	Description	Default	Data type
10001	Active alarms	0	No alarm active		Single Bit
		1	At least one alarm active		Single Bit
10002	Filter alarm	0	Alarm off		Single Bit
		1	Alarm on		Single Bit
10007	Temperature sensor (extract air) status	0	Correct		Single Bit
		1	Error		Single Bit
10008	Temperature sensor (exhaust air) status	0	Correct		Single Bit
		1	Error		Single Bit
10009	Temperature sensor (outdoor air) status	0	Correct		Single Bit
		1	Error		Single Bit
10010	Temperature sensor (supply air) status	0	Correct		Single Bit
		1	Error		Single Bit
10011	Extract air fan status	0	Correct		Single Bit
		1	Error		Single Bit
10012	Supply air fan status	0	Correct		Single Bit
		1	Error		Single Bit
10016	Automatic by-pass	0	Not active		Single Bit
		1	Active		Single Bit
10029	Boost contact status	0	Not active		Single Bit
		1	Active		Single Bit
10030	Boost status	0	Boost active		Single Bit
		1	Boost not active		Single Bit

OUTPUT COILS (Read/Write)					
Modbus Address	Register	Values	Description	Default	Data type
1	Reset filter alarm	0	Do not reset	0	Single Bit
		1	Do reset		Single Bit
8	Manual by-pass	0	Not active	0	Single Bit
		1	Active		Single Bit
9	Allow automatic by-pass	0	Do not allow	1	Single Bit
		1	Allow		Single Bit
10	Summer mode status	0	Off	0	Single Bit
		1	On		Single Bit
17	Manual boost	0	Off	0	Single Bit
		1	On		Single Bit
18	Snooze mode (unit stops for 1h)	0	Off	0	Single Bit
		1	On		Single Bit
26	Working mode	0	Manual	0	Single Bit
		1	Automatic		Single Bit

INPUT REGISTERS (Read only)					
Modbus Address	Register	Values	Description	Default	Data type
30005	Communication error	0	No error		16 bit word
		1	Remote controller		16 bit word
		4	Modbus RTU		16 bit word
30006	Defrost status	0	Not active		16 bit word
		1	Active (fireplace defrost)		16 bit word
		2	Active (with pre-heater)		16 bit word
		3	Active (unbalanced airflows)		16 bit word



INPUT REGISTERS (Read only)					
Modbus Address	Register	Values	Description	Default	Data type
30026	Extract air temperature	-500...+600 d°C	d°C		16 bit word
30027	Exhaust air temperature	-500...+600 d°C	d°C		16 bit word
30026	Outdoor air temperature	-500...+600 d°C	d°C		16 bit word
30026	Supply air temperature	-500...+600 d°C	d°C		16 bit word
30030	Relative humidity extract air	0-100%	%		16 bit word
30031	Relative humidity exhaust air	0-100%	%		16 bit word
30032	Relative humidity outdoor air	0-100%	%		16 bit word
30033	Relative humidity supply air	0-100%	%		16 bit word
30060	Control voltage extract motor	0-100	dV		16 bit word
30061	Control voltage supply motor	0-100	dV		16 bit word
30062	RPM extract motor	0-5000 rpm	rpm		16 bit word
30063	RPM supply motor	0-5000 rpm	rpm		16 bit word
30064	Bypass damper position	0	Closed		16 bit word
		1	Open		16 bit word
		2	Error		16 bit word
30091	Actual working mode	0	Snooze mode		16 bit word
		1	Low speed		16 bit word
		2	Medium speed		16 bit word
		3	High speed		16 bit word
		4	Boost		16 bit word
		5	Auto mode (humidity sensor)		16 bit word
		6	Auto mode (VOC sensor)		16 bit word
		7	Auto mode (0-10V control)		16 bit word
		8	Boost in auto mode		16 bit word
		9	Weekly program 1		16 bit word
		10	Weekly program 2		16 bit word
		11	Weekly program 3		16 bit word
12	Weekly program 4		16 bit word		

HOLDING REGISTERS (Read/Write)					
Modbus Address	Register	Values	Description	Default	Data type
40001	Modbus slave adress	1-247		1	16 bit word
40002	Baudrate	48	4800	192	16 bit word
		96	9600		16 bit word
		192	19200		16 bit word
		384	38400		16 bit word
40003	Modbus parity	0	EVEN	0	16 bit word
		1	ODD		16 bit word
		2	No parity (2 stop bits)		16 bit word
40049	Day	1-31	Day (clock)	Set from factory	16 bit word
40050	Month	1-12	Month (clock)	Set from factory	16 bit word
40051	Year	2016-2100	Year (clock)	Set from factory	16 bit word
40052	Hour	0-23	Hour (Clock)	Set from factory	16 bit word
40053	Minutes	0-59	Minutes (Clock)	Set from factory	16 bit word
40054	Seconds	0-59	Seconds (Clock)	Set from factory	16 bit word
40057	Manual by-pass timer	1-8 h	Manual by-pass timer	8 h	16 bit word
40064	Min ODA for by-pass	120...200 d°C	Minimum outdoor temperature for by-pass activation	130 d°C	16 bit word
40066	Min ETA for by-pass	210-300 d°C	Minimum extract temperature for by-pass activation	230 d°C	16 bit word
40068	Min ETA-ODA for by-pass	30-60 d°C	Minimum difference between ETA-ODA for by-pass	30 d°C	16 bit word
40133	Selected airflow	0	Manual (low airflow)	0	16 bit word
		1	Manual (medium airflow)		16 bit word
		2	Manual (nominal airflow)		16 bit word
		3	Auto		16 bit word
		4	Snooze		16 bit word

10. REPAIRING FAULTS

10.1. MALFUNCTIONS

Malfunction	
The air supplied into the living space is cold.	
Cause	Remedy
The air cools down in the ducts.	<ul style="list-style-type: none"> • Check installation and operation of the system. • Check insulation of outdoor and exhaust air lines.
Supply air fan and extract air fan are not properly balanced.	<ul style="list-style-type: none"> • Adjust airflow rates using a differential pressure gage (see p. 24).

Malfunction	
<ul style="list-style-type: none"> • The ventilation system no longer works. • The fans do not rotate. • The control panel does not work. 	
Cause	Remedy
The mains voltage is interrupted.	<ul style="list-style-type: none"> • Set up the mains voltage again.
A fuse has burned out in the ventilation system.	<ul style="list-style-type: none"> • Call in customer service of the specialised company, check fuse and have it replaced.

Malfunction	
The ventilation system is loud and vibrates.	
Cause	Remedy
A fan is off-balance.	<ul style="list-style-type: none"> • Request customer service from the specialised company, check fan and, if needed, have it replaced.

Malfunction	
The ventilation system is dripping.	
Cause	Remedy
The condensate cannot drain.	<ul style="list-style-type: none"> • Call in customer service of the specialised company and check whether condensate line, condensate vat and syphon dryer are in proper working order; have them cleaned.

Malfunction	
The supply air fan is off.	
Cause	Remedy
Summer mode is ON.	<ul style="list-style-type: none"> • Turn off summer mode, if you no longer desire it, see p. 42.
The anti-freeze protection is on.	 Normal operation of the ventilation system. The symbol is on while anti-freeze protection is activated.

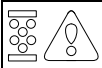
Malfunction	
<ul style="list-style-type: none"> • Calibration of the ServoFlow Kits installed (optional accessory) is not possible. • The LEDs of the fan speeds are blinking. •  The symbol in the control panel blinks 13x red. 	
Cause	Remedy
There is a fault in the device.	<ul style="list-style-type: none"> • Call in customer service of the specialised company. • Check correct connection of the pressure hoses between differential pressure sockets 1 and 2, and also pressure sensors on the ServoFlow Kit. • Check that pressure hoses from the ServoFlow Kit have been laid correctly. The pressure hoses cannot be bent.
The system pressure is too low.	<ul style="list-style-type: none"> • Call in the customer service of the specialised company and have the correct connection of the air lines checked.
The system pressure is too high.	<ul style="list-style-type: none"> • Check whether all ventilation grates, valves and air outlets are open.



10.2. ERROR MESSAGES

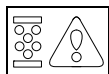

Error messages are displayed by different modes of blinking of the symbol in the control panel. The period between the blinking sequences is roughly 3 seconds.

Malfunction	Symbol	Consequence
A fire alarm was triggered.	It blinks red 1x	The ventilation system stops.
The extract air fan has had a breakdown.	It blinks red 2x	The ventilation system stops.
The supply air fan has had a breakdown.	It blinks red 3x	The ventilation system stops.
The summer bypass has had a breakdown.	It blinks red 4x	The ventilation system stops.
The ServoFlow Kit (optional accessory) has had a breakdown.	It blinks red 5x	The ventilation system stops.
The supply air temperature has dropped below +5°C.	It blinks red 6x	The ventilation system stops. Every 2 hours the ventilation system turns on by itself for 5 minutes in order to check conditions for normal operation.
The temperature sensor outdoor air has had a breakdown (T3 if version A. T1 if version B).	It blinks red 7x	The ventilation system stops.
The temperature sensor supply air has had a breakdown (T4 if version A. T2 if version B).	It blinks red 8x	The ventilation system stops.
The temperature sensor extract air has had a breakdown (T1 if version A. T3 if version B).	It blinks red 9x	The ventilation system stops.
The temperature sensor exhaust air has had a breakdown (T2 if version A. T4 if version B).	It blinks red 10x	The ventilation system stops.
The VOC sensor (optional accessory) has had a breakdown.	It blinks red 11x	The ventilation system is running at fan speed V2.
The preheater (optional accessory) has had a breakdown.	It blinks red 12x	The ventilation system stops.
Calibration of the ServoFlow Kit (optional accessory) is not possible.	The red light blinks 13x, the LEDs of the fan speeds blink	The ventilation system stops.
The pre-set timer for filter replacement has been exceeded.	The red light stays lit	For up to 60 days, normal operation continues to be possible. After that, the ventilation system stops.

11. MAINTENANCE (USERS)

11.1. REPLACING FILTERS

Replacing the filter depends on the degree of pollution of the air (e.g. pollen count, construction site activity, particulate pollution).

The period between filter replacements is set to 12 months at the factory. This period can be reduced or extended depending on air pollution, see Set timer for filter alarm, p. 38.

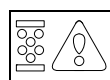

After the period set lapses, the symbol on the control panel lights up.

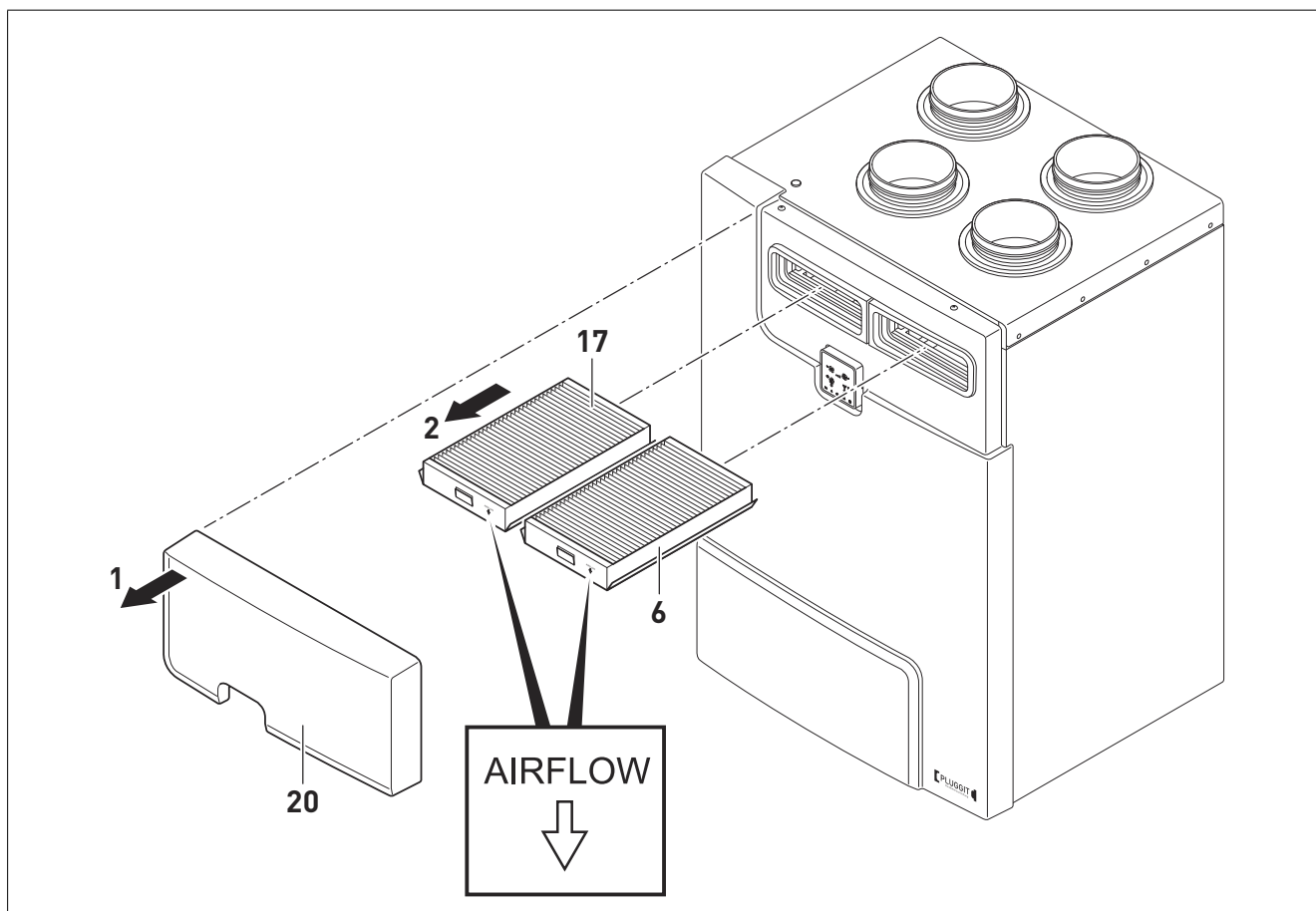

1. Remove filter cover (20) (Arrow 1).
2. Remove used filters (6) and (17) and dispose of them (Arrow 2).
3. Insert new filters. The printed arrows must be positioned downwards toward the middle of the casing.

4.  Hold symbol down for about 5 seconds. The filter alarm is reset.

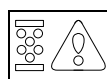

The light on the symbol goes out.

NOTE

Filter spare part code seep. p. 6 (for more information www.solerpalau.com).

12. MAINTENANCE/REPAIRS (SPECIALISTS)



CAUTION

All maintenance and repair tasks described below for the ventilation system may only be carried out by qualified specialists, otherwise there is risk of injuries or damages.



RISK OF INJURY

Disconnect all poles of the ventilation system from the power network before all maintenance and repair tasks, otherwise there is risk of injury.

12.1. MAINTENANCE PERIODS

Maintenance tasks	Annually	Every 2 years
Clean ventilation system, see Clean ventilation system, p. 49.	X	
Clean and fill condensate line, condensate vat and siphon, see Clean ventilation system, p. 49.	X	
Clean heat exchanger, see Clean/replace heat exchanger, p. 50.		X
Clean fan blade, see Clean/replace fan blade, p. 51.	X	

12.2. LOGS PREVENTIVE MAINTENANCE

	Yes	No
Are the fans clean and free of corrosion?		
Do the fans produce no vibrations or noise when operating?		
Can the fan blades turn freely when operating?		
Do the lines and insulation show damages?		

12.3. CLEAN VENTILATION SYSTEM

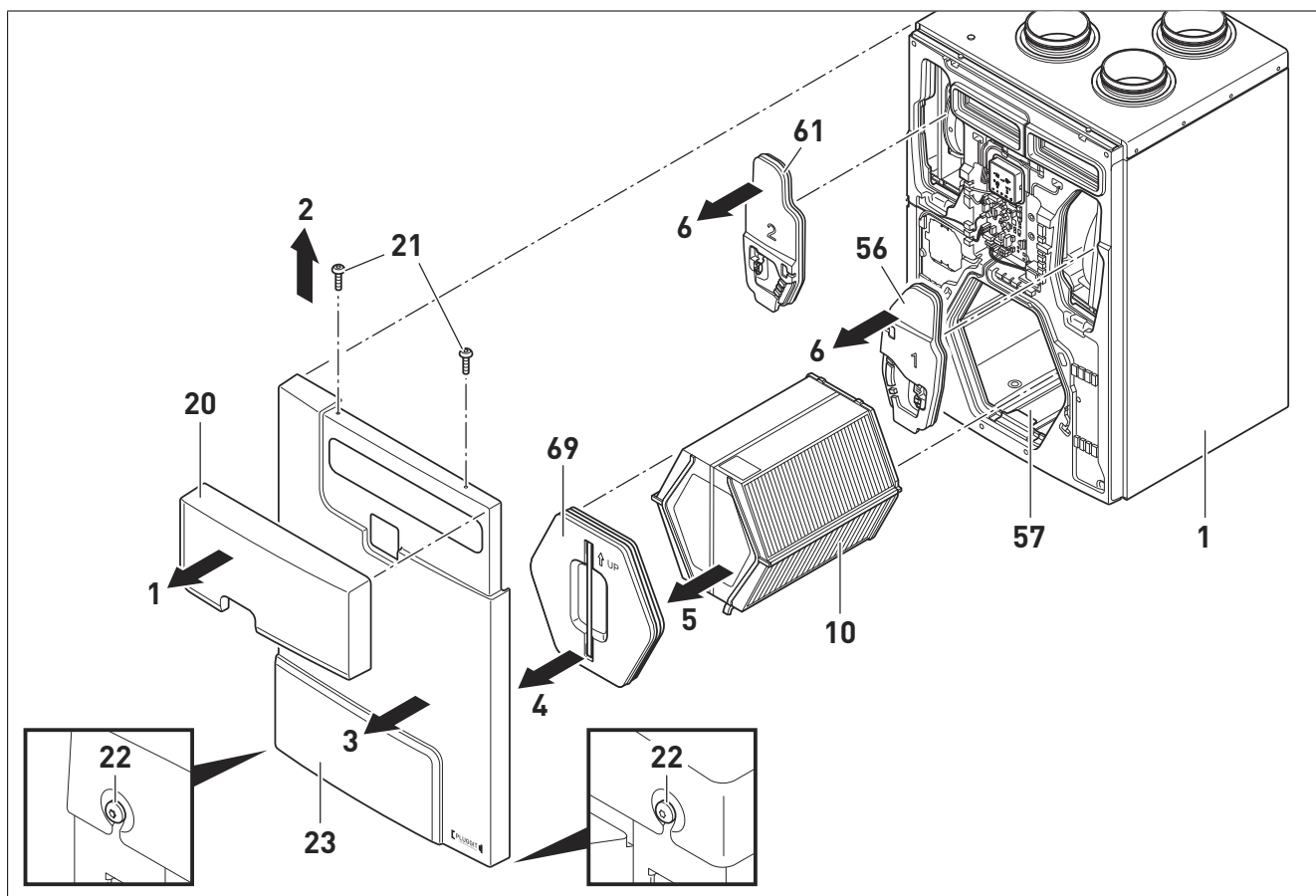

1. Remove filter cover (20) (Arrow 1).
2. Loosen screws Torx 30 (22) on the bottom of the device.
3. Unscrew screws Torx 30 (21) on top of device (Arrow 2).
4. Remove front cover (23) (Arrow 3).
5. Take out heat exchanger cover (69) (Arrow 4).
6. Take out heat exchanger (10) (Arrow 5).
7. Remove connection cables of the fans (56) and (61) on the fan cover, and take off fan cover (56) and (61) (Arrow 6).
8. Clean interior surfaces of the ventilation device (1) and condensate connection including condensate vat (57) with a moist cloth and neutral cleanser.
9. After drying, installation is carried out in the reverse sequence.

12.4. CLEAN/REPLACE HEAT EXCHANGER

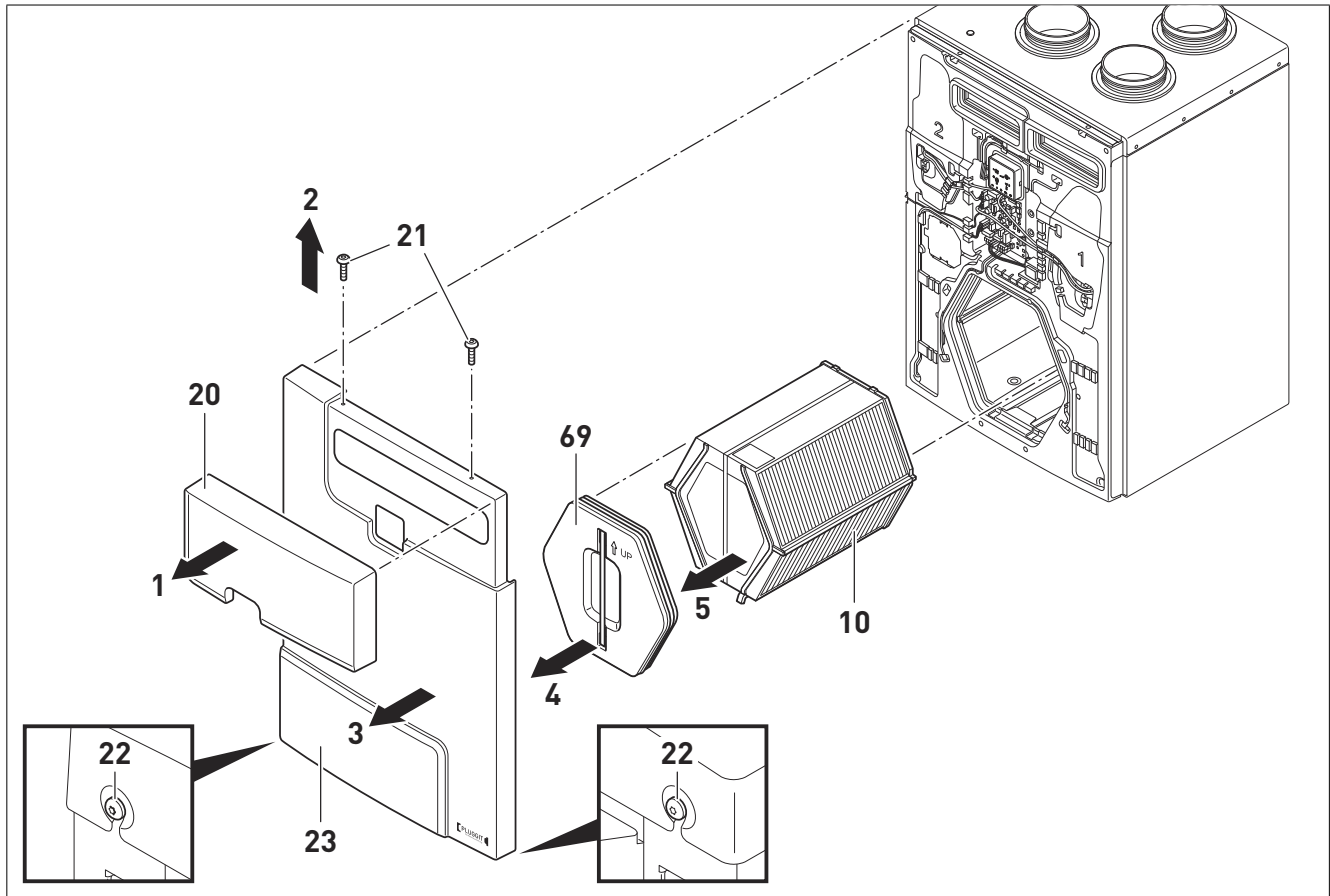

1. Remove filter cover [20] (Arrow 1).
2. Loosen screws Torx 30 [22] on the bottom of the device.
3. Unscrew screws Torx 30 [21] on top of device (Arrow 2).
4. Remove front cover [23] (Arrow 3).
5. Take out heat exchanger cover [69] (Arrow 4).
6. Take out heat exchanger [10] (Arrow 5).
7. Cleaning:
Soak heat exchanger [10] with a mixture of water and cleanser, rinse with clear water, allow all water to drain and allow heat exchanger [10] to dry completely.
8. Replacement:
Take out heat exchanger [10] and replace (Arrow 5).
9. The installation is carried out in the reverse sequence. In this process, pay attention to the direction of installation of the heat exchanger [10].

12.5. CLEAN/REPLACE FAN BLADE

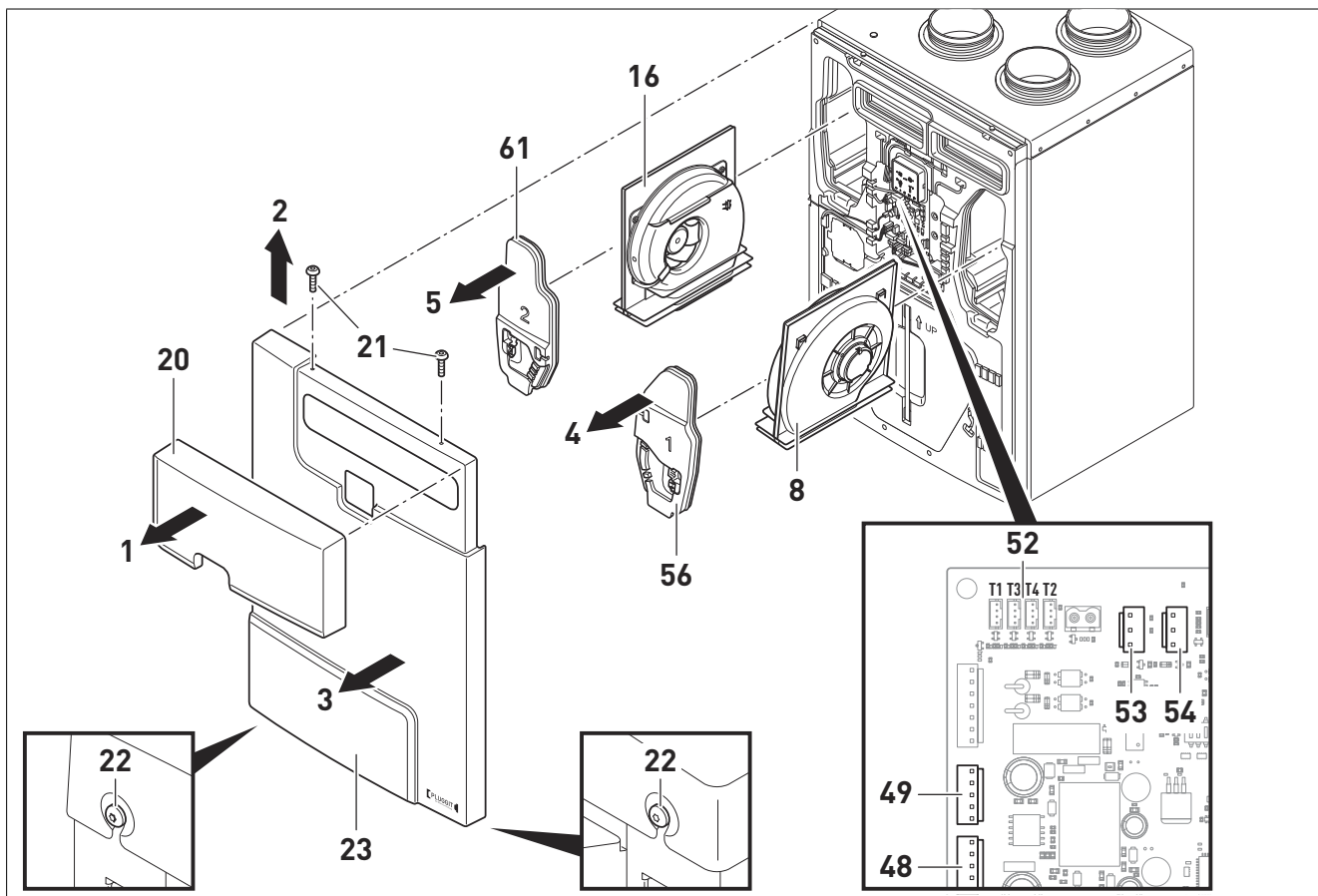

1. Remove filter cover (20) (Arrow 1).
2. Loosen screws Torx 30 (22) on the bottom of the device.
3. Unscrew screws Torx 30 (21) on top of device (Arrow 2).
4. Remove front cover (23) (Arrow 3).
5. Remove connection cables of the fans on the fan cover (56) and (61).
6. Disconnect voltage supply M1 (48) and M2 (49), as well as control signals M1 (54) and M2 (53) on the main circuit board.
7. Cleaning:
 - 7.1. Remove fan cover (56) and fan (8) (Arrow 4).
 - 7.2. Remove fan cover (61) and fan (16) (Arrow 5).
 - 7.3. Clean all fan blades with a brush.
8. Replacement:
 - 8.1. Remove fan cover (56) and fan (8) and replace both (Arrow 4).
 - 8.2. Remove fan cover (61) and fan (16) and replace both (Arrow 5).
9. The installation is carried out in the reverse sequence.

12.6. REPLACE MAIN CIRCUIT BOARD



MATERIAL DAMAGES

When replacing the main circuit board, it must be protected from electrostatic discharge, otherwise there is risk of damages. Avoid electric charge in the body, e.g., by dissipating and earthing of the body.

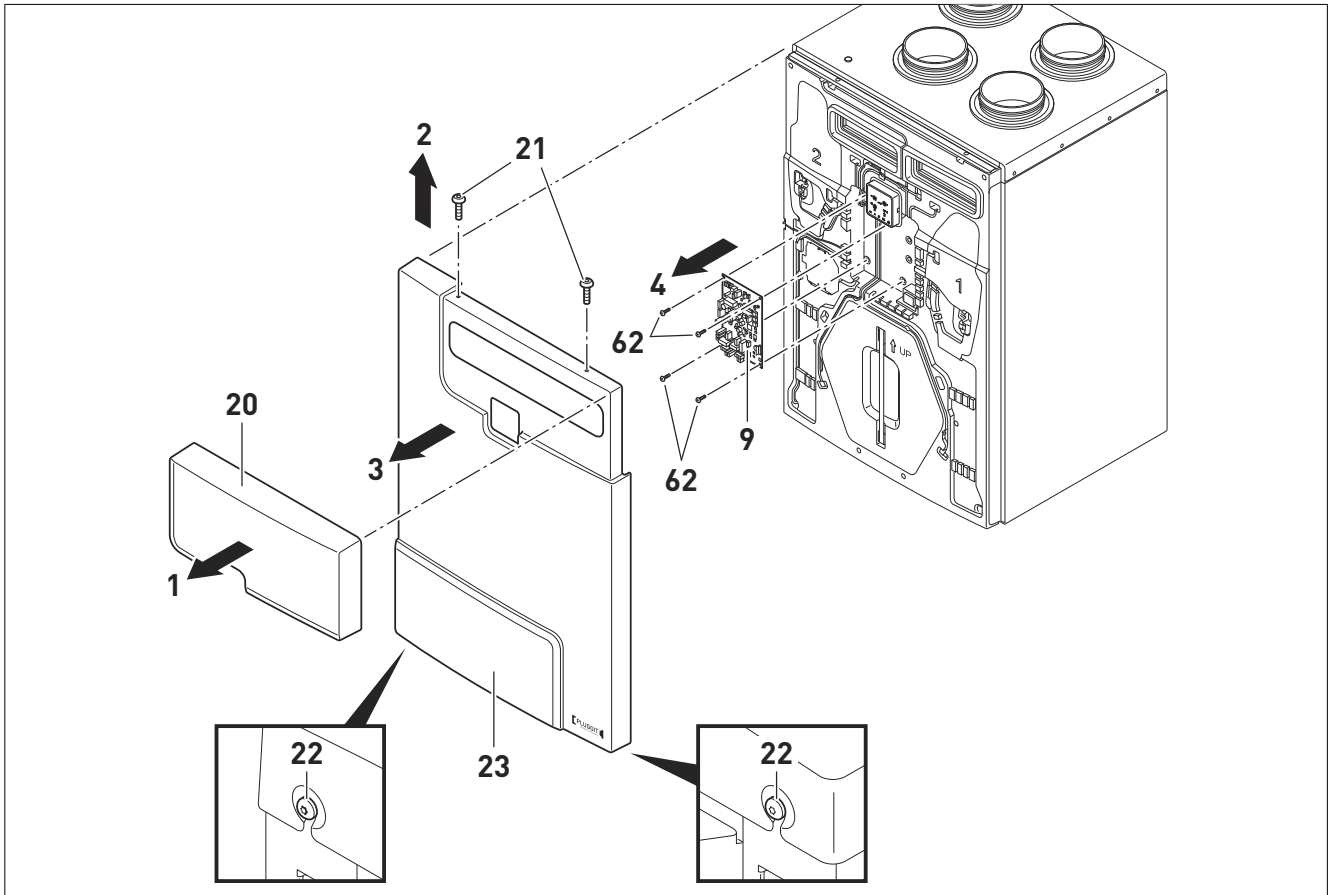

1. Remove filter cover (20) (Arrow 1).
2. Loosen screws Torx 30 (22) on the bottom of the device.
3. Unscrew screws Torx 30 (21) on top of device (Arrow 2).
4. Remove front cover (23) (Arrow 3).
5. Disconnect all plugs on the main circuit board (9).
6. Remove screws Torx 10 (62) and replace main circuit board (9) (Arrow 4).
7. Insert all disconnected plugs on the main circuit board (9), see Circuit diagram main circuit board, p. 9.
8. The installation is carried out in the reverse sequence.

12.7. REPLACE HUMIDITY/TEMPERATURE SENSORS

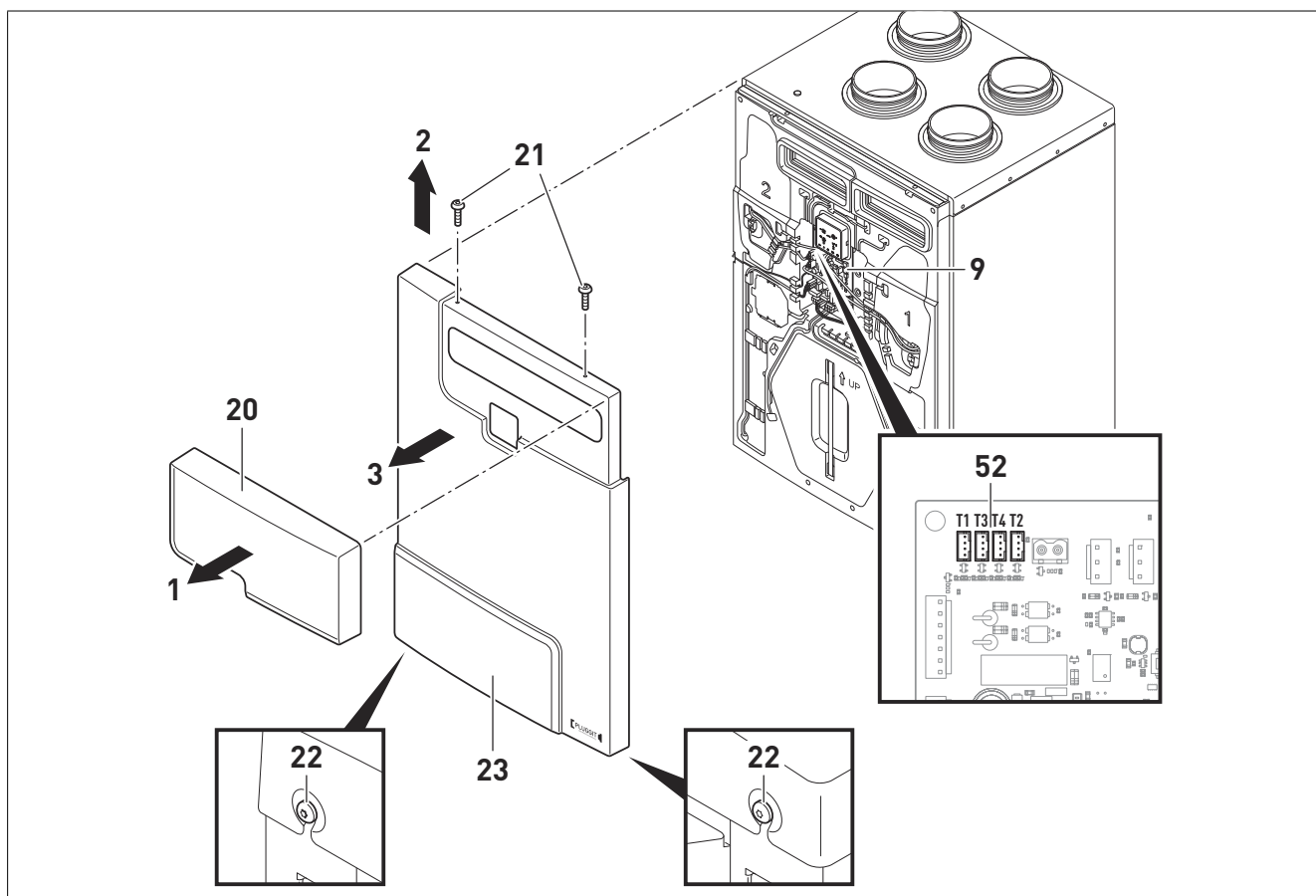

1. Remove filter cover (20) (Arrow 1).
2. Loosen screws Torx 30 (22) on the bottom of the device.
3. Unscrew screws Torx 30 (21) on top of device (Arrow 2).
4. Remove front cover (23) (Arrow 3).
5. Decouple all humidity/temperature sensors from the connection (52) of the main circuit board (9).

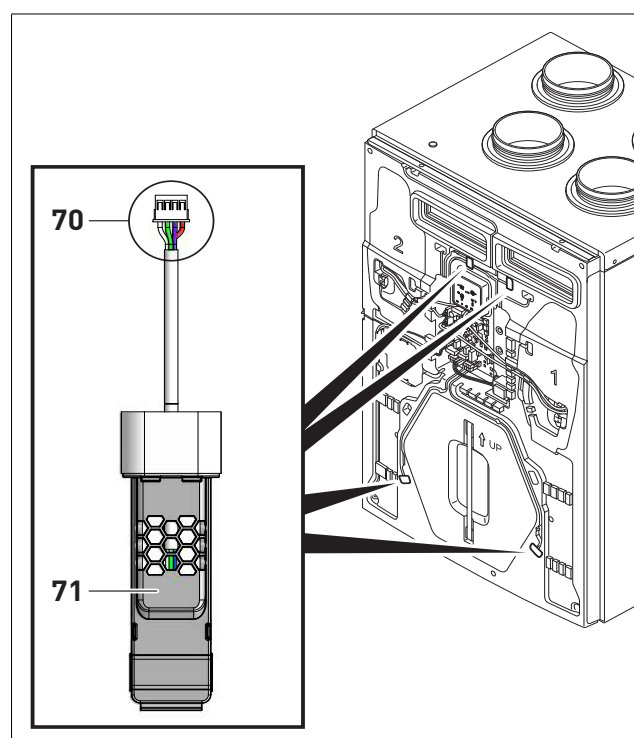

6. Disconnect connection cables (70) from the humidity/temperature sensors (71), and replace humidity/temperature sensors (71).
7. The installation is carried out in the reverse sequence.



13. DECOMMISSIONING/DISPOSAL

13.1. DECOMMISSIONING WITH DISASSEMBLY

The decommissioning may only be carried out by qualified specialists.

- Disconnect system from voltage.
- Disconnect all poles of the entire system from the power grid.

13.2. PACKAGING

The transport and protective packaging is largely made of recyclable materials.

All packaging materials must be disposed of according to local provisions.

13.3. USED DEVICES

The ventilation system contains valuable materials and substances that must not be disposed of with the residual waste. The used device can be handed over for reuse to a local recycling company.

14. PUTTING OUT OF SERVICE AND RECYCLING



EEC legislation and our consideration of future generations mean that we should always recycle materials where possible; please do not forget to deposit all packaging in the appropriate recycling bins. If your device is also labeled with this symbol, please take it to the nearest Waste Management Plant at the end of its serviceable life.

15. ErP DATA

 Ecodesign Commission regulation (EU) N°1253/2014 of July 2014 Information requirements (Annex V)			
Trade mark	SABIK 210	SABIK 350	SABIK 500
Identifier	5153139800	5153139200	5153139300
SEC average climate (kWh/(m ² .an))	-39,3	-39,4	-38,3
SEC class	A	A	A
SEC cold climate (kWh/(m ² .an))	-77	-77	-76
SEC warm climate (kWh/(m ² .an))	-15	-15	-14
Typology	UVR bidirectional		
Type of drive	Variable speed drive		
Type of HRC	Recuperative		
Thermal efficiency (%)	86,7	85,4	85,4
Maximum flow rate (m ³ /h)	225	360	540
Electrical power input at maximum flow rate (W)	90	145	265
Sound power level (LWA)	49	50,5	53
Reference flow rate (m ³ /s)	0,044	0,074	0,105
Reference pressure difference (Pa)	50	50	50
SPI (W/m ³ /h)	0,25	0,23	0,28
Control factor	0,85	0,85	0,85
Control typology	Central demand		
Maximum internal leakage for BVU (%)	0,7	0,4	0,5
Maximum external leakage for BVU and UVU (%)	1,8	0,3	0,5
Mixing rate for BVU without duct connection (%)	Not applicable		
Position of visual filter warning	Remote control		
Description of visual filter warning	Pilot light		
Instructions to install supply grilles	Not applicable		
Instructions to install exhaust grilles	Not applicable		
Internet address	www.solerpalau.com		
Airflow sensitivity to pressure variation	Not applicable		
Indoor/outdoor air tightness (m ³ /h)	Not applicable		
Annual electricity consumption - Average climat (kWh/a)	271	253	298
Annual electricity consumption - Warm climat (kWh/a)	226	208	253
Annual electricity consumption - Cold climat (kWh/a)	808	790	835
Annual heating saved - Average climat (kWh/a)	4540	4505	4505
Annual heating saved - Warm climat (kWh/a)	2053	2037	2037
Annual heating saved - Cold climat (kWh/a)	8882	8813	8813



S&P SISTEMAS DE VENTILACIÓN, S.L.U.

C. Llevant, 4
Polígono Industrial Llevant
08150 Parets del Vallès
Barcelona - España

Tel. +34 93 571 93 00
www.solerpalau.com



Ref. 9023102302