



Range of industrial cooling fans designed to provide high volumes of air. The fan casing is formed from heavy gauge rolled sheet steel with the motor support manufactured from steel rod and electro-welded for increased strength. The fan assembly is supported by a robust cold formed tubular steel stand. The whole assembly is protected by cataforesis primer and black polyester paint finish. Plastic impellers dynamically balanced manufactured in a UV stabilised injection moulded plastic with reinforced fibreglass resistant to many chemical and abrasive airstreams. All models are fitted with robust steel wire finger guards on both the inlet and outlet sides of the fan. All wiring connections are made via an IP65 rated terminal box fixed to the exterior of the casing and provided with 2 poles On/Off switch.

Motors

All the motors are IP65, Class F insulation (1), equipped with thermal protection. Three phase motors are speed controllable by inverter. All motors are speed controllable except /4-630 model. Electrical supplies:
Single phase 230V-50Hz.
(Capacitor located inside the wiring terminal box).
Three phase 230/400V-50Hz.

(1) Class F insulation: working temperatures from -40°C up to 70°C.

Additional Information

Standard air direction: form (B) configuration (Impeller over Motor).



Inlet bellmouth
Aerodynamic design of the inlet bellmouth to optimise airflow performance and minimise noise level.



Flame retardant terminal box
Wiring terminal box in flame retardant plastic V0 fixed to the exterior of the casing and provided with a two-pole On/Off switch. Cable gland PG-11.

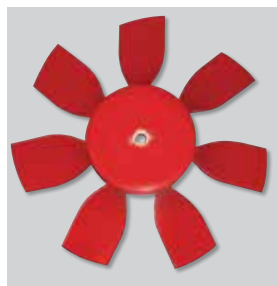

Impeller dynamically balanced
Impellers are dynamically balanced, according to ISO 1940 standard, giving vibration free operation.

TECHNICAL CHARACTERISTICS

Before installation check that the product electrical characteristics listed on the data plate label (voltage, power, frequency, etc.) match those of the intended electrical supply.

SINGLE PHASE Model	Speed (r.p.m.)	Max. absorbed power (W)	Max. current (A)	Maximum air volume (m³/h)	Sound pressure level at 1,5 m (dB(A))	Weight (Kg)	Speed controller
PBB/4-315	1300	100	0,6	2.250	54	13,5	REB-1
PBB/4-400	1200	340	1,6	5.200	60	20	REB-2,5
PBB/4-450	1290	480	2,3	6.700	65	26	REB-2,5
PBB/4-560	1250	980	4,9	12.300	71	39	REB-5
PBB/4-630	1200	1700	7,6	16.450	74	40	-

THREE PHASE Model	Speed (r.p.m.)	Max. absorbed power (W)	Max. current (A)		Maximum air volume (m³/h)	Sound pressure level at 1,5 m (dB(A))	Weight (Kg)	Speed controller
			230V	400V				
PBT/4-315	1300	150	0,59	0,34	2.250	54	13,5	RMT-1,5
PBT/4-400	1200	300	1,4	0,8	5.200	60	20	RMT-1,5
PBT/4-450	1290	500	1,7	1	6.700	65	26	RMT-1,5
PBT/4-560	1250	1210	3,9	2,3	12.300	71	39	RMT-2,5
PBT/4-630	1200	1600	4,84	2,8	16.450	74	40	-

DIMENSIONS (mm)

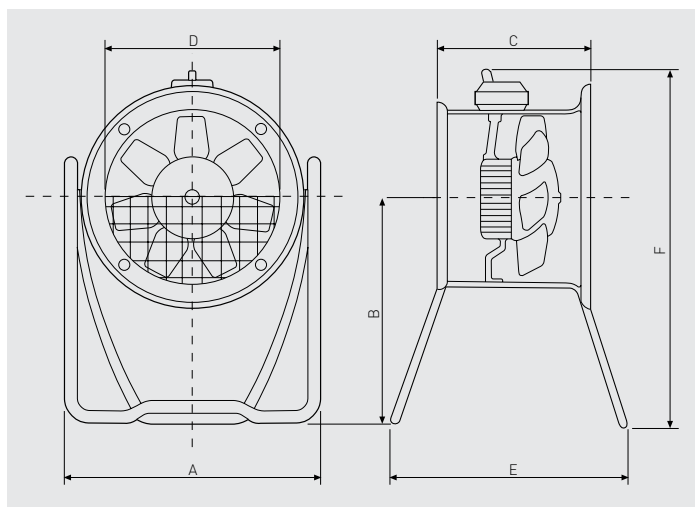

Model	A	B	C	ø D	E	F
315	439	400	211	315	470	642
400	600	557	227	400	560	841
450	650	616	237	450	560	925
560	780	473	307	560	500	837
630	890	750	307	630	840	1149

ELECTRICAL ACCESSORIES



REB
 Single phase electronic speed controllers.



RMB
 Single phase auto transformer speed controllers.



RMB
 Three phase auto transformer speed controllers.

AIR THROW CURVES

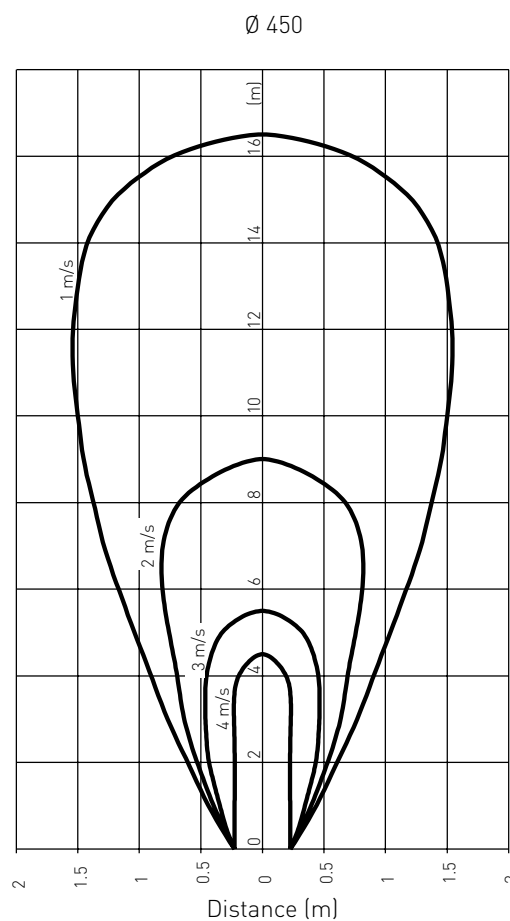
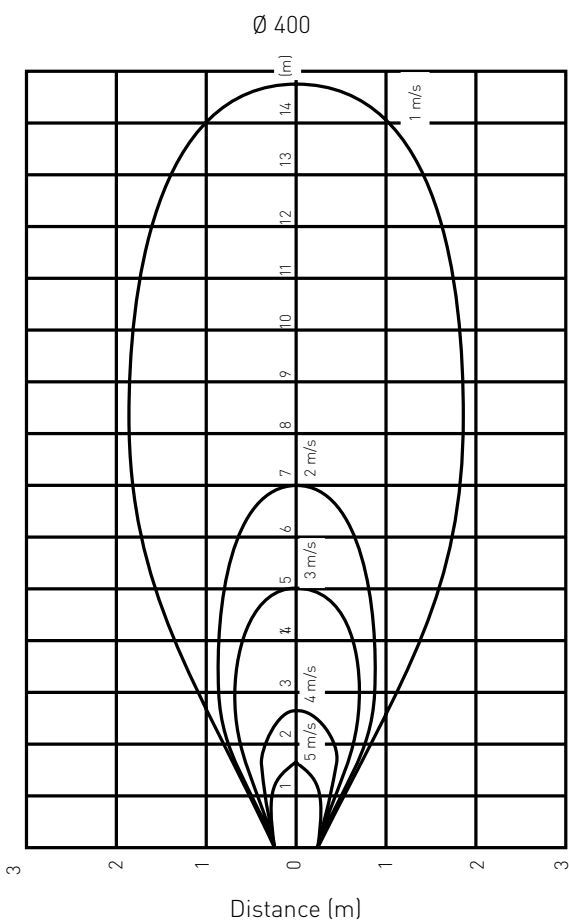
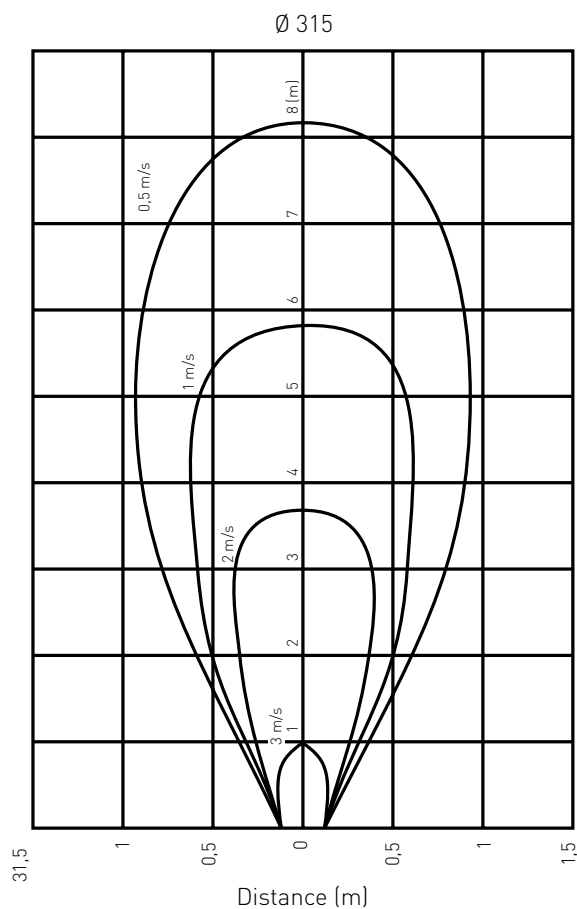

CURVAS DE PROYECCIÓN DE AIRE

Ø 560

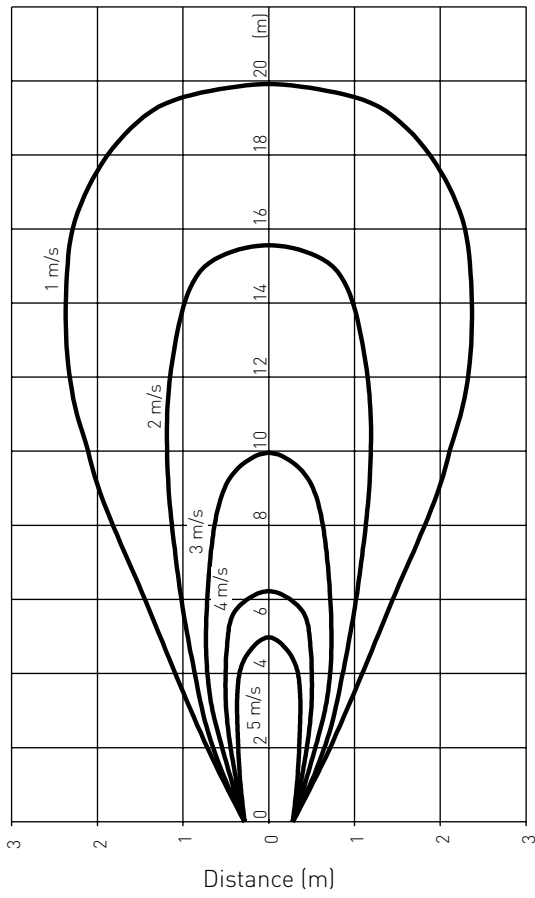

Ø 630

