

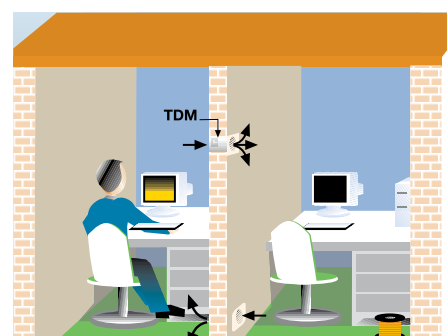

Model TDM-300

The TDM series of axial fans have been specifically designed to be installed in low pressure ducted systems. Single phase motor 230V-50Hz, Class II, IPX4. Protected against overheating. Suitable to operate within temperatures up to 40°C. The "Z" versions incorporate long life motors fitted with ball bearings.

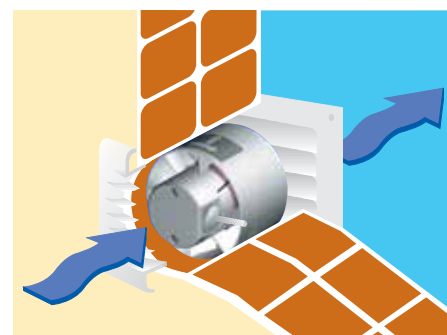

Models 100 and 200 can be installed within a wall to provide exhaust air operation or to exchange heat between adjacent rooms.

TECHNICAL CHARACTERISTICS

Model	Speed (rpm)	Maximum absorbed power (W)	Ø Duct (mm)	Air volume at free discharge (m³/h)	Sound pressure level * (dB(A))	Weight (kg)	Electric scheme* (nº)
TDM-100	2500	13	100	110	40	0,4	2, 3
TDM-200	2600	25	125	200	44,5	0,6	2, 3
TDM-300	2200	35	150	300	45	1,5	2, 3

* See section Electric Schemes.

DIMENSIONS (mm)

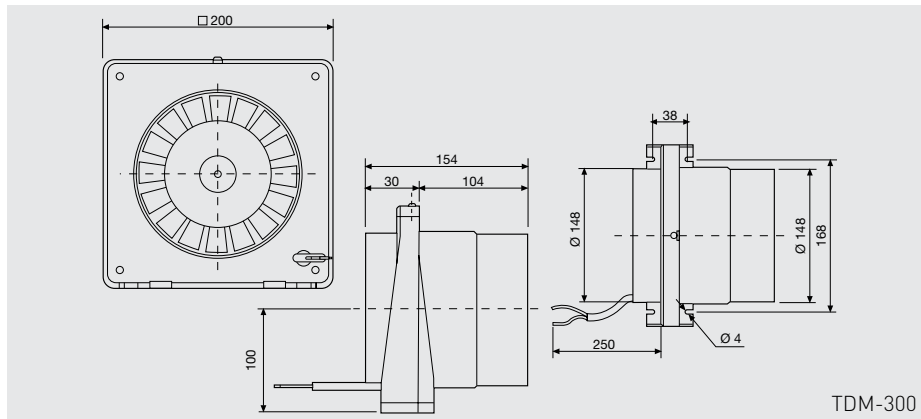
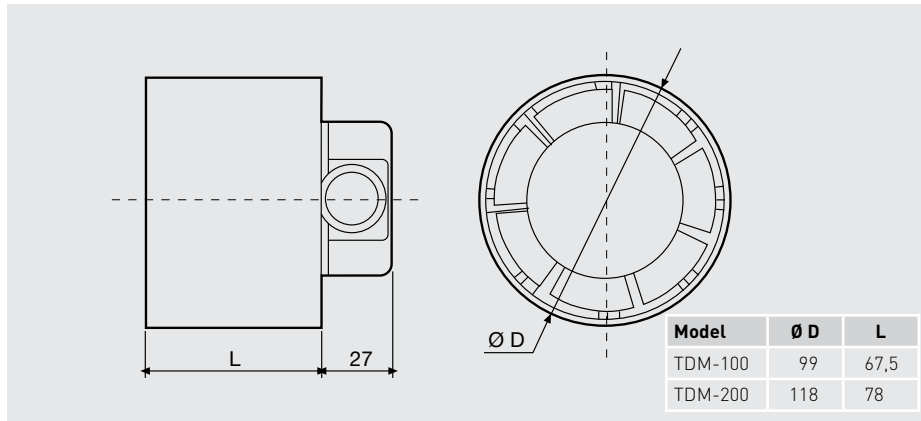

PERFORMANCE CURVES

- q_v : Air volume in m^3/h and m^3/s .
- p_{sf} : Static pressure in Pa.
- Dry air at $20^\circ C$ and 760 mmHg.
- Performance data in accordance with ISO 5801 and AMCA 210-99 Standards.

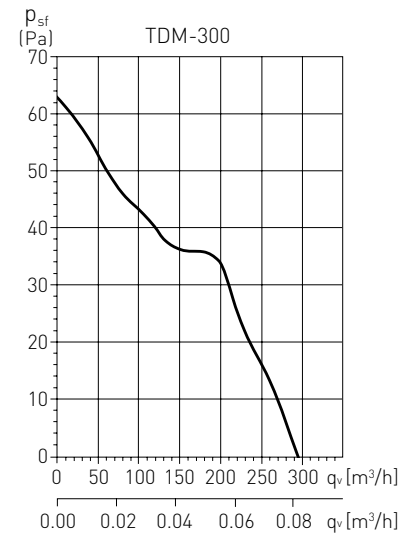
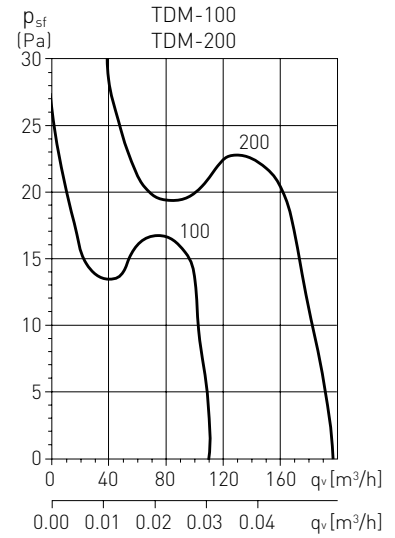

ACCESSORIES



**Mounting foot
PIE-100/120**
Support for wall fixing
(accessory).



GSA
Flexible aluminium
ducting.



**GRA-100
GRA**
Exterior aluminium
discharge guard.



CX
Worm drive clips.



PER-W
Plastic back draft
shutters.

Accessories	Discharge guard	Back draft shutters	Worm drive duct clamps	Aluminium flexible ducting
TDM-100	GRA-100	PER-100W	CX-80/125	GSA-100
TDM-200	GRA-100	PER-125W	CX-125/215	GSA-125
TDM-300	GRA-150	PER-160W	CX-125/215	GSA-150